

**CETACEAN MONITORING SYSTEM
MARINE MAMMAL DETECTION AND TRACKING
TECHNICAL OVERVIEW**



USA
Seamap Inc.
10801 Hammerly Boulevard
Suite 206
Houston TX 77043

Tel : +1 713 690 2228
Fax : +1 713 690 2255

Email : info-usa@seamap.com

ASIA
Seamap Pte, Ltd
Blk 2, Loyang Lane
#05-03 Loyang Industrial Estate
Singapore 508913

Tel: +65 6545 1054
Fax: +65 6545 0585

Email : info-asia@seamap.com

EUROPE
Seamap (UK) Limited
Unit 31, The Maltings
Charlton Estate
Shepton Mallet
Somerset BA4 5QE
United Kingdom
Tel : +44 (0) 1749 342223
Fax : +44 (0) 1749 347588
Email : info-uk@seamap.com

Email : support@seamap.com
Web : www.seamap.com

COPYRIGHT AND DISCLAIMER NOTICE

The following document contains confidential information belonging to Seamap Pte. Ltd. and all use and sales rights are reserved. The information is expressly for a specific purpose and the user, by accepting this information, agrees that it may not be partially or wholly copied or distributed to any third party or used for any other purpose than that for which it was intended without express written consent from Seamap Pte. Ltd.

All product names referenced herewith are trademarks of their respective companies. Use of a term in this document should not be regarded as affecting the validity of any trademark or service mark.

Seamap Pte Ltd. reserve the right to modify or make changes to any product mentioned within this document, and the information contained within this document is subject to change without notice. Any changes will be notified to the holder of the document at the discretion of Seamap Pte. Ltd.

Inquiries about this document or its contents can be made to:

USA

Seamap Inc.

10801 Hammerly Boulevard
Suite 206
Houston TX 77043

Tel : +1 713 690 2228
Fax : +1 713 690 2255

Email : info-usa@seamap.com

ASIA

Seamap Pte, Ltd

Blk 2, Loyang Lane
#05-03 Loyang Industrial Estate
Singapore 508913

Tel: +65 6545 1054
Fax: +65 6545 0585

Email : info-asia@seamap.com

Email : support@seamap.com
Web : www.seamap.com

EUROPE

Seamap (UK) Limited

Unit 31, The Maltings
Charlton Estate
Shepton Mallet
Somerset BA4 5QE

United Kingdom
Tel : +44 (0) 1749 342223
Fax : +44 (0) 1749 347588

Email : info-uk@seamap.com

AMENDMENT CONTROL

Amendments to this document will be agreed with the approval signatories. Amendments will be accompanied by an amendment number and instructions on how the amendment is to be incorporated. Recipients are responsible for incorporating amendments and completing the amendment record.

AMENDMENT RECORD

ISSUE/ AMENDMENT NO.	DATE	SECTION/ PAGE	CHANGE DETAILS	INCORPORATED BY DATE
3.0	10/10/03	All	Formatting, Update of photographs, Inclusion of Appendices	

DISTRIBUTION LIST

SERIAL NO.	PERSON	COMPANY	COPIES

TABLE OF CONTENTS

1	Introduction	5
2	Components	6
3	Marine Mammal Acoustics Overview	9
4	Essential Techniques	
	4.1 Correlation	12
	4.2 Digital Filtering	15
5	Cetacean Monitoring Software	16
	5.1 Click Detection Tool	17
	5.2 Ultra Low Frequency Tool	18
	5.3 Spectrographic Tool	19
	5.4 Scope Tool	22
	5.5 Map Viewer	23
6	Cetacean Monitoring Hardware	24
7	Specifications	25
8	Appendices	
	8.1 Cetacean Monitoring System FAQ	26
	8.2 Passive Acoustic Survey Activity List	28
	8.3 Marine Mammal Acoustic Recording Form	29
	8.4 Industry Guidelines	30

LIST OF FIGURES

2.1	System Overview	6
2.2	Onboard System	7
2.3	Standard Towing Configuration	8
2.4	Port/ Starboard Ambiguity Resolution	8
3.1	Acoustic Arrivals at Hydrophone	10
3.2	Noise Sources in the Ocean (indicative purposes only)	11
4.1	Bearing Calculation for Acoustic	12
4.2	Signal Correlation used to Derive Bearing	14
4.3	Digital Filtering Process	16
5.1	Typical Software Display showing CMS software and Map Viewer	17
5.2	Click Detector	18
5.3	Ultra Low Frequency Tool – blue whale	19
5.4	Humpback Whale Song	20
5.5	Sperm Whale Clicks with a rubber band area selected by the operator	21
5.6	Selected area post processed	22
5.7	Scope Tool	22
5.8	Map Viewer	23
6.1	Display and Streamer Interface Unit	24
6.2	Recording Unit	24
6.3	Deployment of Streamers	24

1. Introduction

Seamap's Cetacean Monitoring System utilises the most advanced engineering in passive acoustic technology to detect, monitor and track marine mammals.

There is increasing interest in the potential impact offshore industry activities have on the marine environment. Specific concern focuses on the effect that human-generated, high-intensity acoustic pulses may have on a number of whale and dolphin species.

In many cases the effects are not yet known and a number of investigative research programmes have been established to determine the environmental impact.

Marine mammal observers have been introduced as independent monitors for a variety of offshore-based activities though their effectiveness is limited as they can only operate during daylight hours and in calm seas. Critically, their performance is also hindered by the fact that the mammals spend most of the time under the waves and out of sight.

Seamap has addressed these limitations.

With a combination of extensive experience in the design and production of offshore equipment including towed arrays, coupled with the expertise to create innovative software applications, Seamap has engineered a complete robust integrated solution for detection, monitoring and tracking of marine mammals using passive acoustics.

The system offered by Seamap consists of a low noise in-sea towed hydrophone array tethered to the main vessel by an umbilical. The complete cable assembly is designed with careful attention to the reduction of noise characteristics and the associated improvement in signal to noise ratio.

Signals from this in-sea system are routed to the onboard equipment by a molded deck cable where they are amplified and processed using state of the art hardware and software technology.

The system is capable of estimating range as well as calculating bearing to a high degree of accuracy for almost any coherent sound source. The software continuously monitors hydrophone data, depth information and GPS location and utilizes advanced signal processing techniques on this data to report the location of the source. This integration of information into a single system provides the best possible tool for real-time marine mammal detection.

By monitoring broadband signals from 8 Hz to over 22 KHz the system is capable of detecting nearly all whale vocalisation and echolocation energy. The dynamic range of the system is also sufficient to detect many species of whales at ranges of many kilometers.

2. Components

The Seamap Cetacean Monitoring system consists of several interconnected components. Deployed from a winch is the lead-in that connects the passive acoustic array to the vessel. Inside the array are several high frequency hydrophones used to detect the marine mammal vocalisations. The array also contains a precision depth transducer used to continuously monitor the tow depth of the equipment.

The lead-in is connected to the onboard system by means of a deck cable. This provides a conduit for the streamer power as well as the signal paths for the data from the hydrophones to the onboard system.

The onboard system consists of several interconnected components that are designed to be 19" rack mounted. As an option, the system comes pre-configured in a 19" rack mount transit case staged ready for use.

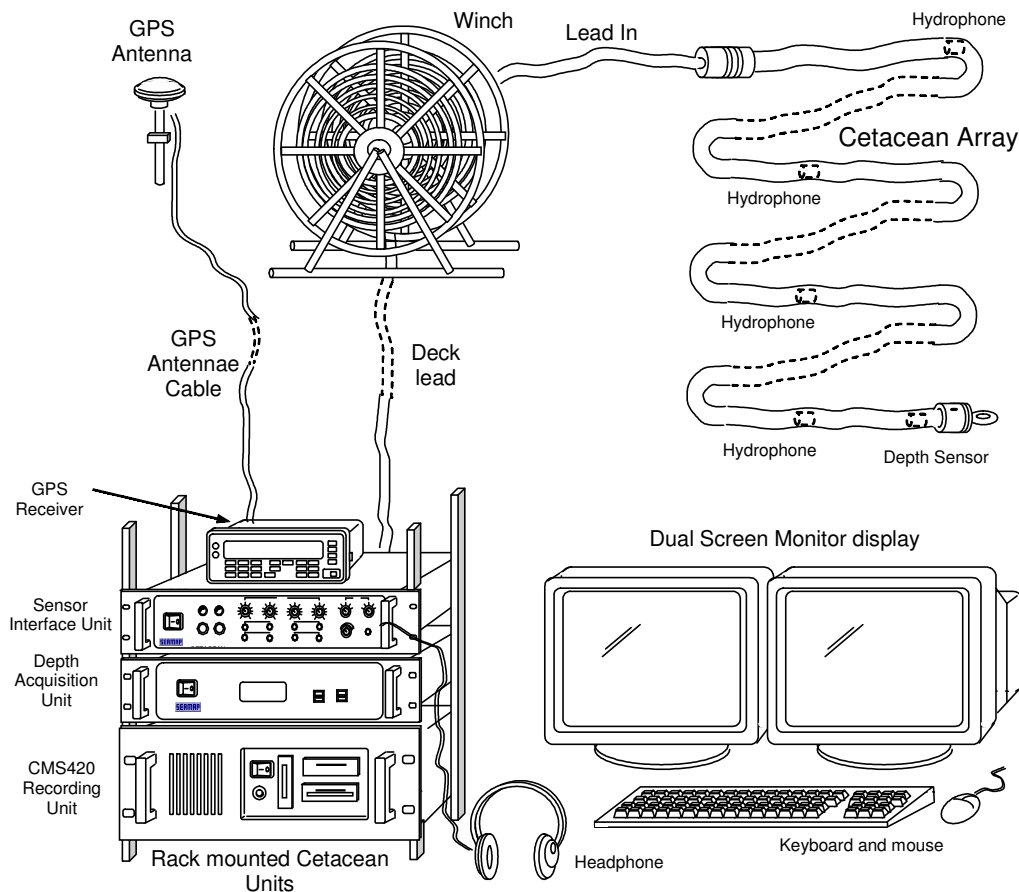

Fig 2.1 System Overview

The onboard system components are shown in the figure below. The Streamer Interface Unit is used to provide power to the in sea hydrophone preamplifiers as well as providing filtering, configurable gain and a headphone connection for four

hydrophone channels in the towed array. The streamer interface has two sets of buffered analogue outputs available, one is used by the CMS 420 acquisition unit, and the other is available for other recording or analysis options such as DAT or similar.

The Depth Acquisition unit interfaces to up to 4 depth transducers and provides an RS232 data string output which is interfaced to the CMS 420 recording unit. This allows the system to continuously monitor the array depth, for safety as well as system performance reasons.

The CMS 420 recording unit is a multiprocessor industrial PC which is used to digitize, process and analyze the hydrophone data. The CMS 420 is the platform that runs the whale detection monitoring and tracking software and supports the users dual screen workstation.

The system also comes with an optional GPS receiver and antenna. This GPS receiver is interfaced to the CMS 420 recording unit to provide continuous vessel position to assist in location of the detected animals.

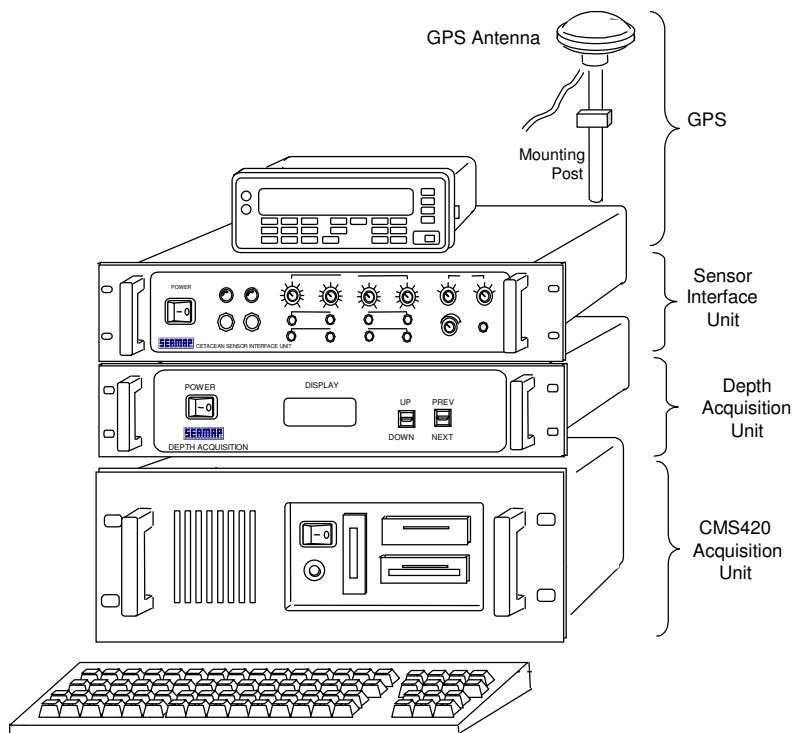

Fig 2.2 Onboard System

The diagram below shows the standard towing configuration when using a single cable streamed behind a vessel. The system is ballasted to tow at forty meters if operational conditions allow. If this tow depth cannot be achieved, for example when

the water depths don't allow, the system can be ballasted to operate at a shallower depth, but the system detection range will be slightly reduced.

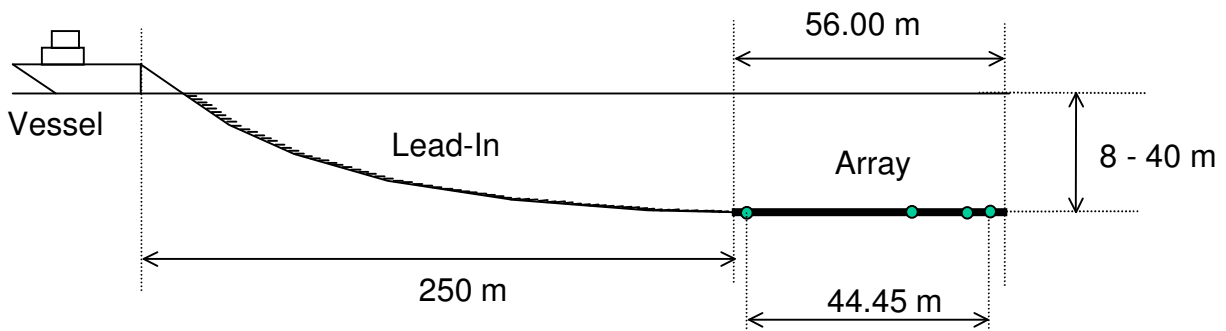

Fig 2.3 Standard Towing Configuration

When the system is operated with a single cable there is a port/starboard ambiguity when calculating bearing to an animal. This is because the hydrophones in a single array all lie along the same axis. If hydrophones are towed in a two-dimensional plane, for example when a second cable is deployed, then the port/starboard ambiguity can be resolved. The Seamap system was always designed with this in mind, and is therefore able to cover this future requirement. For most operations the port/starboard ambiguity can be resolved by taking several fixes to the animal over a short period of time. With small heading changes of a few degrees between these detections, the bearings to the animal are resolved and the ambiguity disappears.

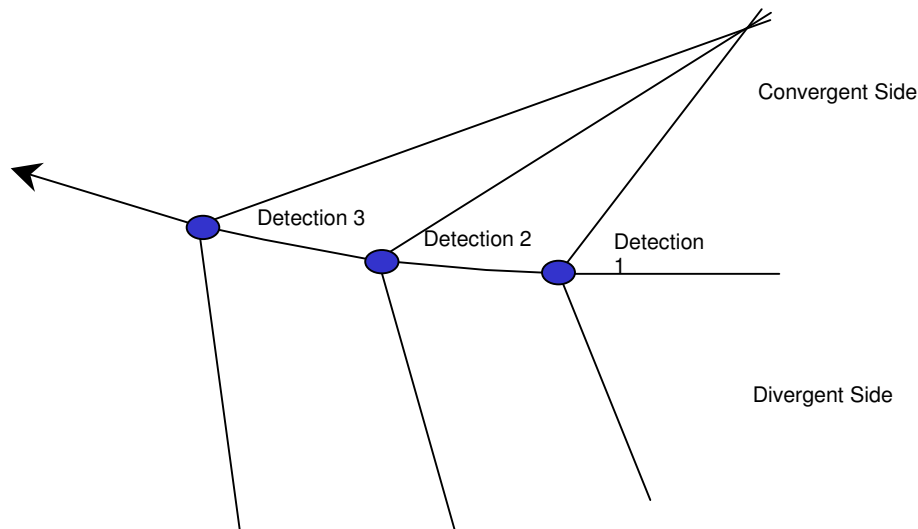

Fig 2.4 Port/Starboard Ambiguity Resolution

3. Marine Mammal Acoustics Overview

Most whales and dolphins are highly vocal animals using sounds to echolocate food and to navigate. It is also believed that the vocalisation of whales is part of a complex communication protocol between the animals.

Seamap's passive acoustic monitoring system listens to the sounds produced by the animals and provides the tools allowing the operator to identify the animal species as well as estimate range and bearing to the animal. Seamap's passive system puts no additional acoustic energy into the environment so it can be used even when there is an absolute requirement for unobtrusive detection methods.

The analysis of sub sea sounds requires knowledge of the physics of sound propagation in water. Firstly the speed at which sound travels in water is several times faster than the speed of sound in air. The velocity in water is approximately 1500 meters per second (the precise speed varies depending on temperature and density of the seawater) compared to the approximate speed in air of 330 meters per second. Using knowledge of arrival times at hydrophones and the distance between them combined with the speed of sound allows the system to calculate the incident angle of coherent acoustic energy at the hydrophones. Secondly, as sound propagates away from the source of the energy it gets quieter, as a rule of thumb for deep water and short distances the energy is reduced by half for every doubling of distance. So, if you measure energy of x at one meter from the source of the sound, you would expect the energy to be half that at two meters and half again at four meters, half again at eight meters and so on. This effect is generally described by the term "Spherical Divergence"

The whole picture of underwater sound propagation becomes complicated when the acoustic energy is measured with significant reflected energy arrivals from the surface or from the seabed. When acoustic energy meets a boundary layer where the density of the medium changes, for example the air to water boundary, or the water to seabed boundary, a proportion of the energy is reflected back from the boundary and some of the energy is transmitted through it. Depending on whether the energy is passing from a medium to a less dense medium or from a medium to a denser determines the phase of the reflected energy.

Different medium pairs are attributed different reflection coefficients based upon the amount of energy reflected from the boundary. The reflection coefficient shows the proportion of the energy that would be reflected. This number lies between 0.0 and 1.0. The reflection coefficient is given a sign indicating if the reflected energy is phase inverted or not. In the case the energy is traveling in a dense medium and strikes a boundary of less dense material the reflected energy will be inverted and the reflection coefficient will be given a minus sign. If the reflection coefficient is close to 1.0 or -1.0 this indicates that almost all of the energy would be reflected back from the boundary layer, if the reflection coefficient is close to zero then most of the energy would be transferred through the boundary layer. The water air interface is

often said to be an almost perfect reflector of acoustic energy and has a reflection coefficient of close to -1.0 .

Predictions about the reflected energy are in reality troublesome due to the continuous changing shape of the surface due to wave and swell motion. For wavelengths of sound significantly shorter than the wavelengths of the surface waves this scattering can be likened to a faceted mirror where the facets of the mirror are continuously changing. For wavelengths of sound that approach, or are longer than the wavelength of the surface waves, the effect is much less and the plane reflecting surface assumption becomes more accurate. In depth discussions about this problem are beyond the scope of this document.

The reflection coefficient for the water seabed boundary is generally a positive number lying in the 0.25 to 0.75 range. The reason for the wide span of reflection coefficients is due to the many different types of seabed, mud, sand, corral, rock etc. that are found in different areas. The reflection coefficient is a positive number because the seabed is denser than the water. This positive reflection coefficient means that the sound is reflected with the same phase as the incident acoustic energy, but because the absolute value is significantly less than 1.0 the proportion of sound reflected is reduced when compared to the incident energy. The remainder of the energy not reflected is transmitted through the boundary layer into the seabed itself.

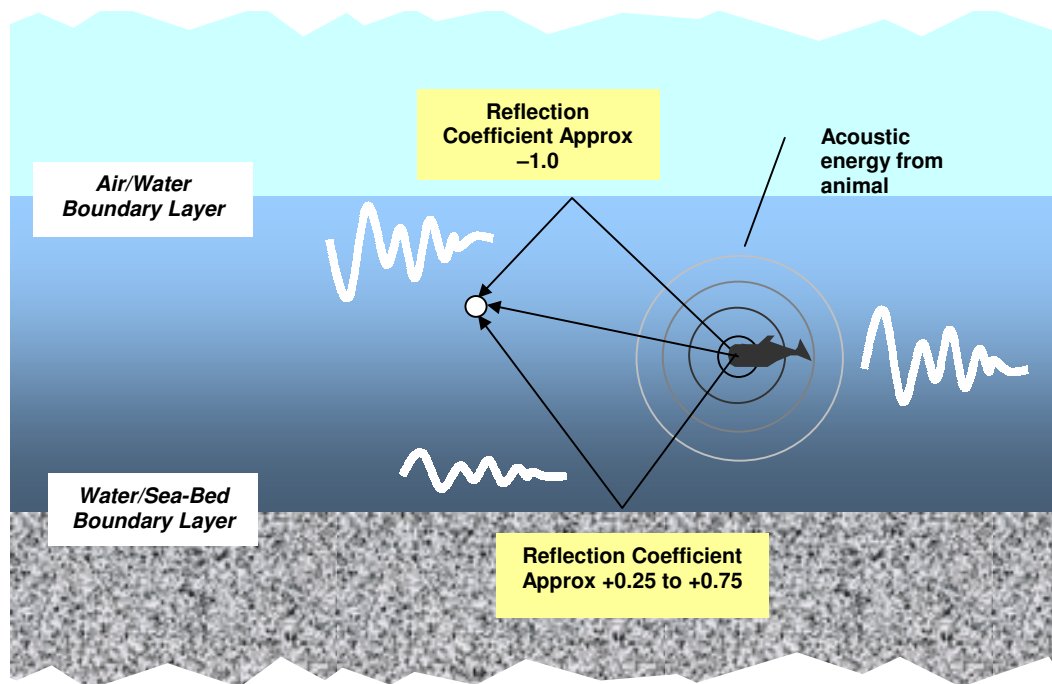

Fig 3.1 Acoustic arrivals at hydrophone

When using a hydrophone to receive the acoustic energy in the sea, the arrival of these reflected signals would also be detected as echoes delayed in time due to the

longer travel time for the hydrophone. The amplitude of the arrival will also depend on the travel path length because of spherical divergence. The illustration below shows a view of the sound energy that would arrive at a hydrophone in the field. In reality the picture would be even more complicated by the whale-surface-seabed-hydrophone and whale-seabed-surface-hydrophone possible arrival paths. These combination arrival paths are called multiples and can be seen in some circumstances to reverberate for a very long time.

There are many sound sources to be found in the oceans, some from natural phenomena, such as earthquakes or volcanic eruptions, others are man made such as Low Frequency Active Sonar or the sounds generated by a marine seismic airgun source. The amplitude over time and frequency content of these signals is often referred to as the signature of the source. The diagram below is indicative of some of the more common, and some not so common, sources of sound that can be found in the oceans today. The illustration shows the maximum signal level on the vertical

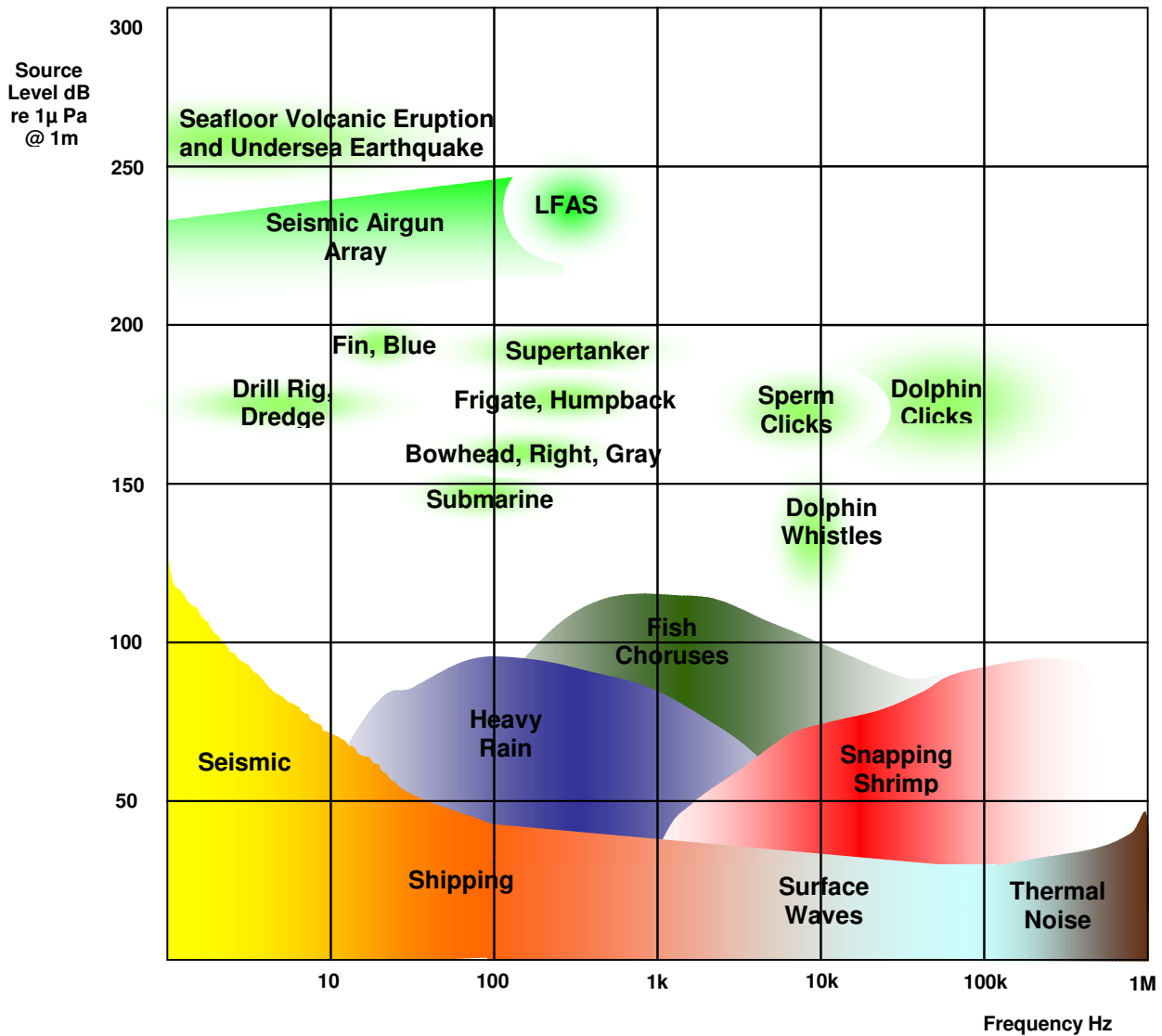

Fig 3.2. Noise Sources in the ocean (indicative purposes only)

scale and frequency content on the horizontal scale.

One of the important points illustrated by the above diagram is that many sound sources that can be heard in the oceans lie within a certain narrow frequency ranges. One of the methods that allows the discrimination of a dolphin whistle from say ship noise is to limit the frequencies analysed to just the narrow frequencies that dolphin whistles lie within. By filtering out all other frequencies we can make sure any direction finding or analysis of the data won't be confused by other sound sources that lie in different frequency ranges. It should also be noted that the marine mammal vocalisations are significantly louder than the background noise in the oceans related to distant seismic (exploration as well as natural occurrences), shipping, wave & rain noise as well as the noises associated with fish and snapping shrimp.

It is clear that the frequency and amplitude of marine mammal vocalisation lend themselves to being detected by passive acoustic techniques.

4. Essential Techniques

4.1 Correlation

By analysing the time delay of a signal's arrival from one hydrophone to another assuming the source of the acoustic source to be in the far field, it is possible to determine the incident angle of the acoustic signal arriving at the phone pair and, if the signal is from a marine mammal, determine the direction to the animal. The figure below shows how the incident angle can be measured for a dipole system (hydrophone pair).

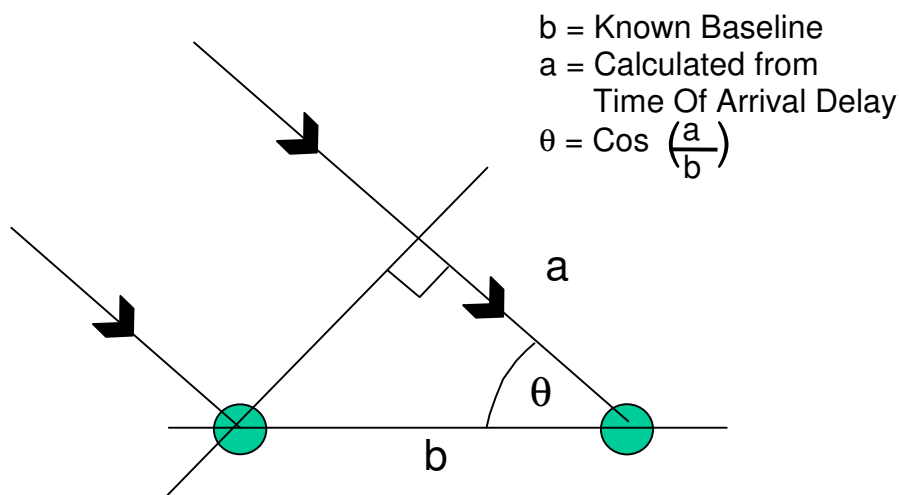

Fig 4.1 Bearing Calculation for acoustic

The concept of determining the incident angle is one that is reasonably easy to understand. The problem comes when knowing how to determine the time of arrival delay between a sound arriving on the first hydrophone and one arriving on the second hydrophone. The method used to find the time of arrival delay is correlation. This is a mathematical tool that can be applied to find the best fit when comparing a known signal source with an unknown one. In application the principle is that a certain segment of acoustic data is selected from one hydrophone signal stream. This data is then slid over the signal from the other hydrophone both forwards and backwards in time to generate the correlation function of the two signals. The amount of time forward and backward to compare the two signals is chosen to correspond to the maximum travel time between the hydrophone pair (b in Fig. 4.1 above). The correlation function will generate a positive peak when there is a best match between the two signals. The time delay of the two signals at the time of this peak in the correlation can be used to calculate the extra distance the sound must have traveled before arriving at the hydrophone (a in Fig. 4.1 above). Fig 4.2. below demonstrates the process of correlation of two signals.

The figure below shows the process where a small segment of data is selected on one channel because it is known to emanate from a marine mammal.

This signal is correlated with the signal from the second hydrophone from $-t$ to $+t$.

The value of t is chosen to be the maximum possible delay in time from one hydrophone to the other. This maximum time would occur then the signal arrives at the hydrophone pair inline with the axis. As an example, if the hydrophones were 15m apart and the speed of sound was assumed to be 1500m/s then the sound wave would take 10ms to travel the 15m distance between the hydrophones. From this we can work out the number of correlation frames required to derive the whole correlation function.

Assuming we sampled the data at 44100 times per second then 441 samples would have been taken in the time that it takes the sound wave to travel 15m. Because a sound could take +10ms to travel from hydrophone 1 to hydrophone 2, it is also true that a sound travelling from hydrophone 2 to hydrophone 1 would also take +10ms, this can be viewed as if it were -10ms from hydrophone 1's time frame.

Because of this forward and backward in time view of the data we need to correlate both forward and backwards in time. In our example we need to correlate from +10ms to -10ms. This equates to 441 correlation frames for each direction plus one for $t=0$ i.e. 883 correlation frames.

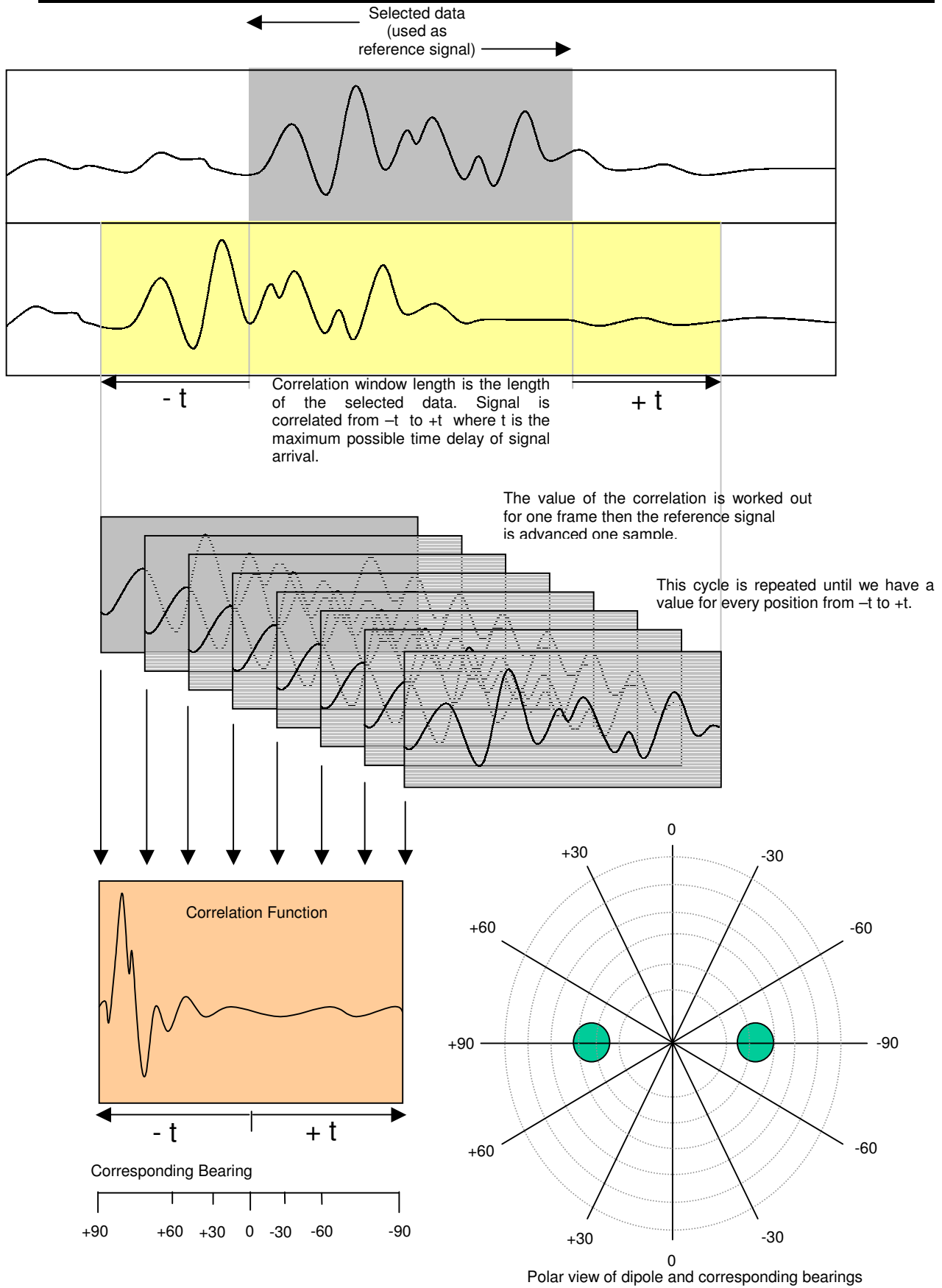

Fig 4.2. Signal Correlation used to derive bearing

4.2 Digital Filtering

It is possible to create digital filters that can create almost any response curve desired for a signal stream. The method used by Seamap's Cetacean Monitoring System is to take the raw digitised data from the hydrophones, pass it through a windowed fast fourier transform to get the signal into the frequency domain then convolve the signal with the response curve of the filter we wish to apply. The windows are overlapped by 50% and a window applied to stop edge effects from distorting the output signal.

The figure below shows the stages required in applying a continuous digital filter using a windowed FFT. The stages are described as follows:-

- Data samples are windowed with each window having a 50% overlap with the previous window.
- The first blue window shows an individual frame of sample data.
- The next shows the windowing function that is applied to the data. This reduces the possibility of edge effects in the processed data.
- Then we see the result of multiplying the individual frame of sample data with the windowing function.
- Then we see the data represented in the frequency domain. This is achieved by applying the FFT algorithm.
- Next a filtering function is applied.
- Frequency data is convolved with the filter function.
- Then there is data in the time domain again after applying the inverse fourier transform.
- Finally we see the individual data windows being summed to create the filtered data signal.

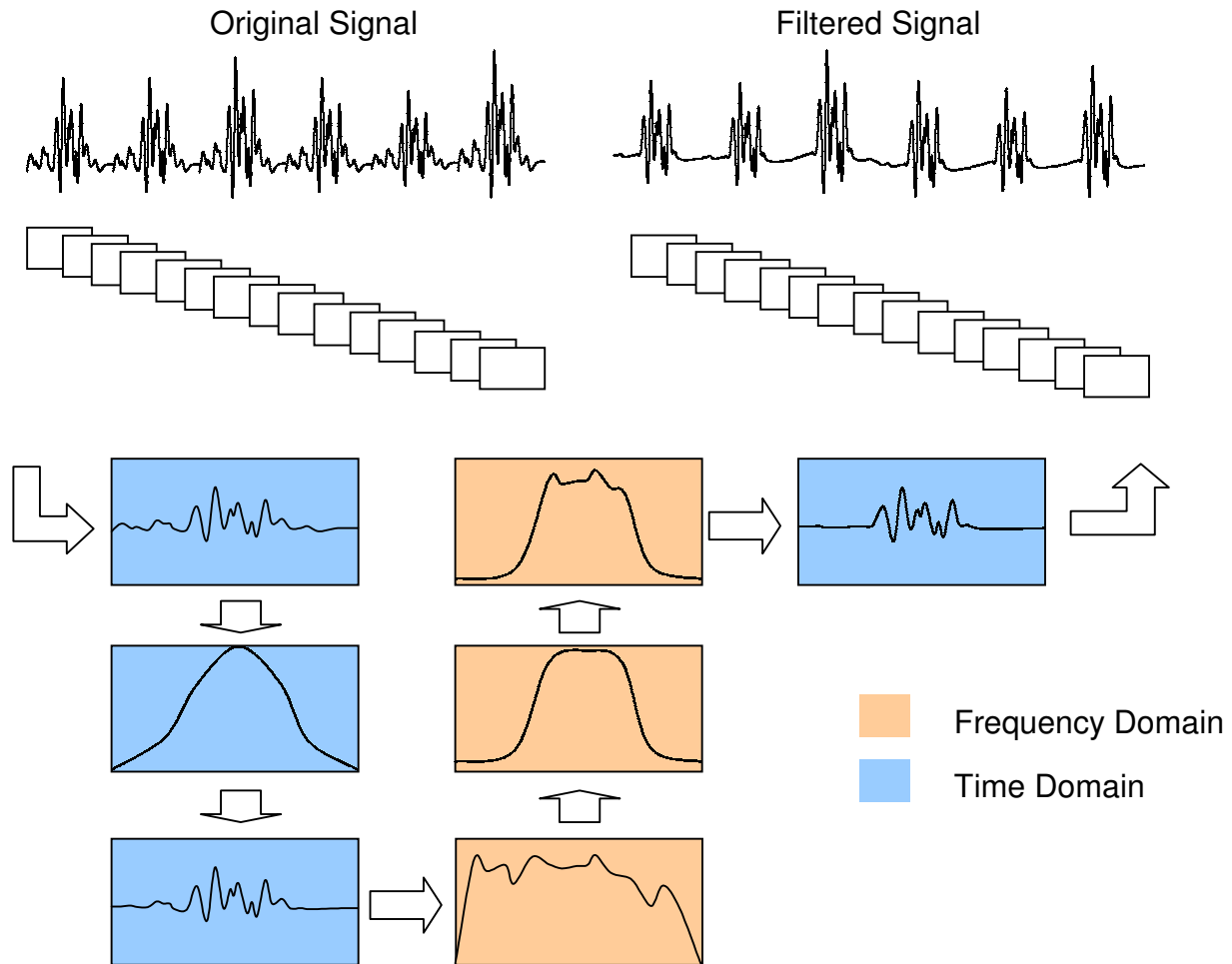

Fig 4.3. Digital Filtering Process

5. Cetacean Monitoring Software

This section of the overview will attempt to explain some of the tools available to the operator within the software. Once a basic understanding of what is being displayed is conveyed, it becomes clear to the operator how to best configure the system to maximize performance for the intended (frequencies) sound source(s) of interest. Multiple sound targets can be configured and displayed simultaneously to simplify the operators task of monitoring a variety of whale or dolphin detections.

Because of the large range of software tools that may need to be displayed, the system is normally supplied configured to use dual displays which allows for several windows to be in view at any one time.

It should also be remembered that these displays are user configurable and optional depending on the frequencies of interest and type of acoustic signals you are trying to detect. If you wish to monitor for multiple species, distant seismic as well as ship and drilling noise then you are likely to have many windows open. If you are only interested in a single species such as sperm whales for example then it may not be necessary to have all the displays running.

Over the next few pages the main tools of the software will be covered in a little more detail.

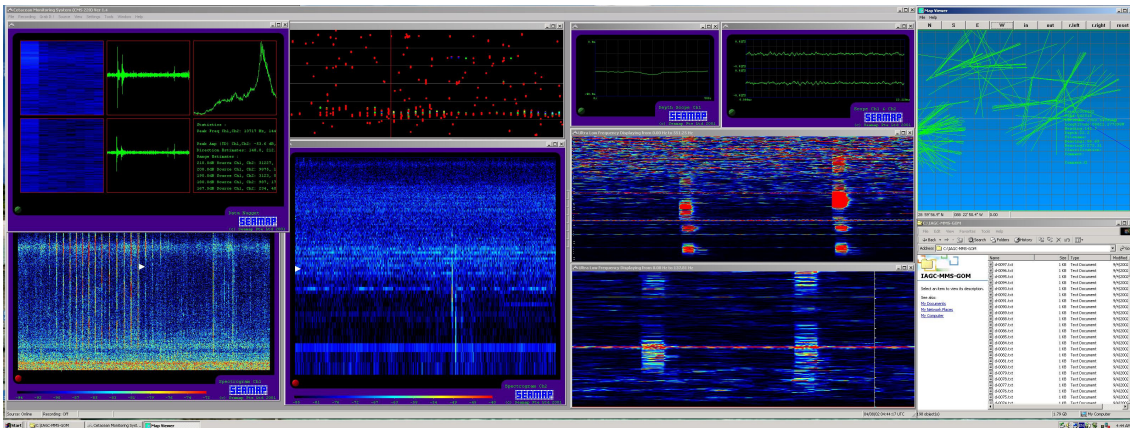

Fig 5.1. Typical Software Display showing CMS software and Map Viewer

5.1 Click Detection Tool

The click detection tool provides all the required functionality to detect and calculate the bearing to “transients” once arriving on the phones. The system works by continuously monitoring a single channel. The system measures the standard deviation of the signal received and compares this to the standard deviation of the background noise. If the background standard deviation is exceeded by n (where n is a user configurable value) then the system extracts that noisy section from the monitored channel and compares that section with the other channel. The system finds the best match with this section of data in the other channel using the correlation technique described elsewhere in this document. Using knowledge of the speed of sound in water and baseline length between the phones, the system calculates the representative incident angle of the signal and plots a point on the display.

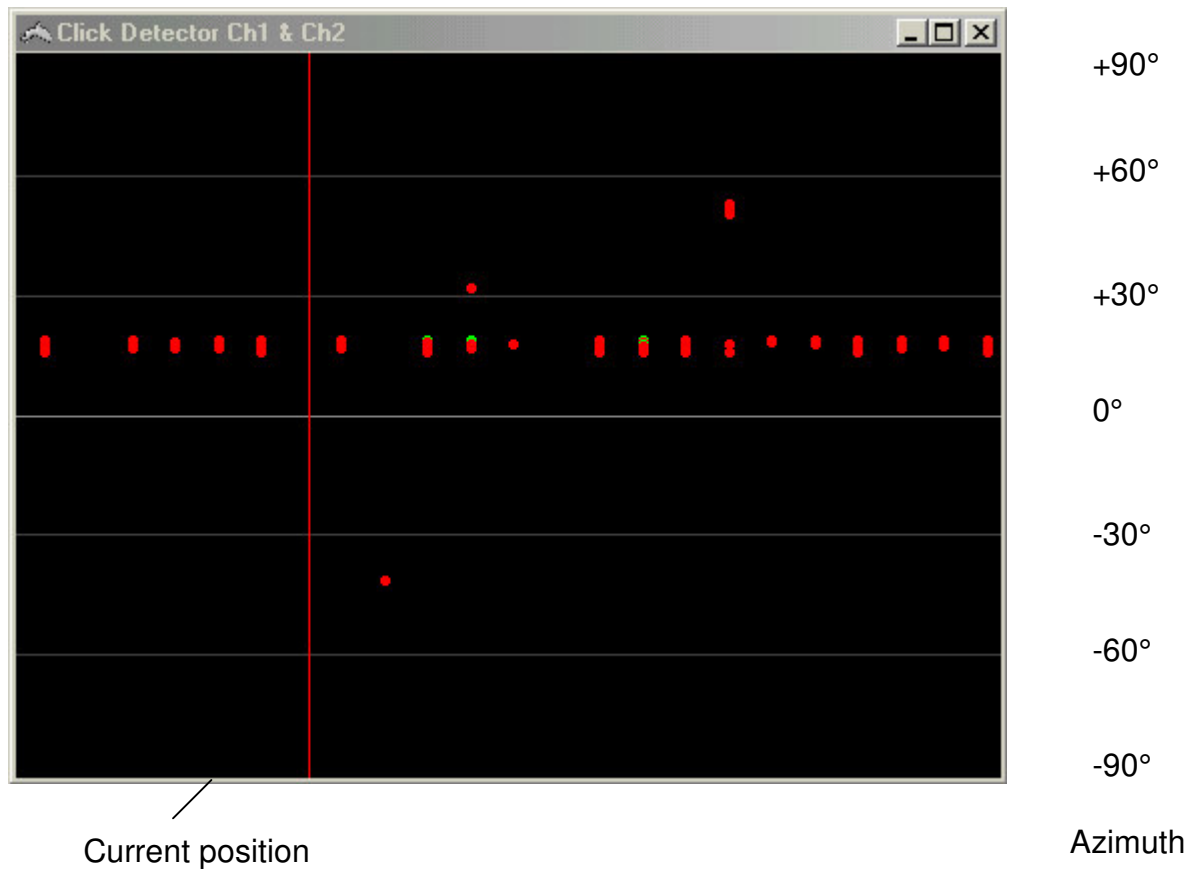

Fig 5.2. Click Detector

The click detection tool is ideal for detecting the echolocation clicks of whales, including dolphins, beaked whales and sperm whales.

5.2 Ultra Low Frequency Tool

The ultra low frequency tool provides a frequency domain view of low frequency data. The display is configurable for FFT bin size, under sampling parameters the overlap of the FFT windows. By providing extreme flexibility to the user in choice of operational settings it is possible to examine the ultra low frequencies in as much detail as required for a particular purpose. The figure below shows the vocalisation of the Blue Whale easily visible when using this display. The mysticetes or baleen whales vocalize at extremely low frequencies, extending into the infrasonic. Some of these vocalisations aren't possible to be heard with the human ear, it is therefore essential to be able to visualize these frequencies for the operator to be able to detect such whales.

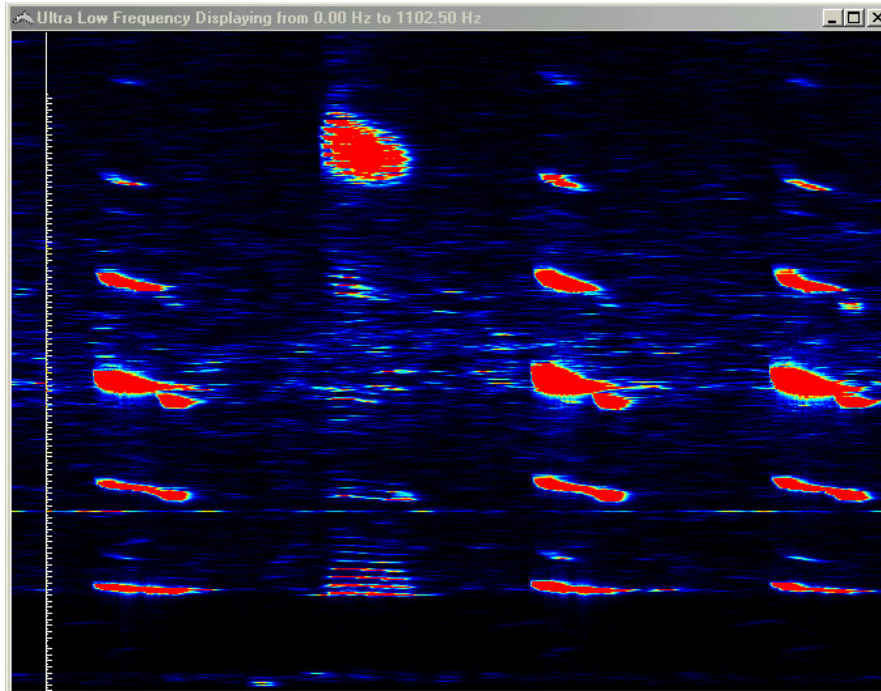

Fig 5.3. Ultra Low Frequency Tool – Blue Whale

5.3 Spectrographic Tool

The spectrographic tool provides a broadband view of the data. The operator, as required, can set the upper and lower frequency bounds of the display. Low frequencies are displayed near the bottom of the display and rise towards the top. It is an option that the vertical scale be logarithmic to provide an enhanced view for the lower frequencies. Time is represented by horizontal position and the white arrow shows the position of the latest updated data. Intensity of acoustic energy at a particular frequency is shown by the color intensity at that location on the screen, the intensity scale at the bottom of the display shows which colors are used for a particular dB relative to full scale.

The figure below shows a humpback whale song with its complex harmonics displayed.

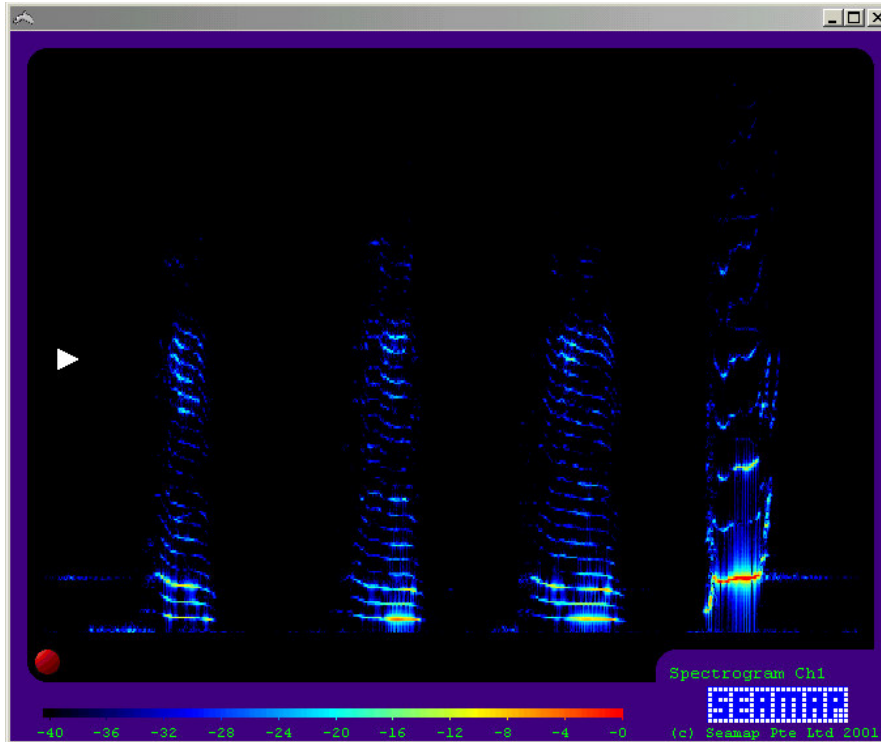

Fig 5.4. Humpback Whale Song

The spectrographic tool screen shot below highlights an important feature. The operator can select any region from this display for further analysis by using the left mouse button and rubber banding an area of the display. The system will then extract the data for the bounded region, band pass filter the data selected between the upper and lower frequency bounds of the region selected by the operator, then correlate the processed data with the second channel to determine the incident angle of the significant energy selected. Below we can see the spectrographic tool being used with sperm whale clicks. The operator has selected a single click to be analyzed and by limiting the bounding frequencies, has eliminated any extraneous lower or higher frequencies from being included in the analysis. The following page shows the results of the rubber banding analysis tool (Data Nugget).

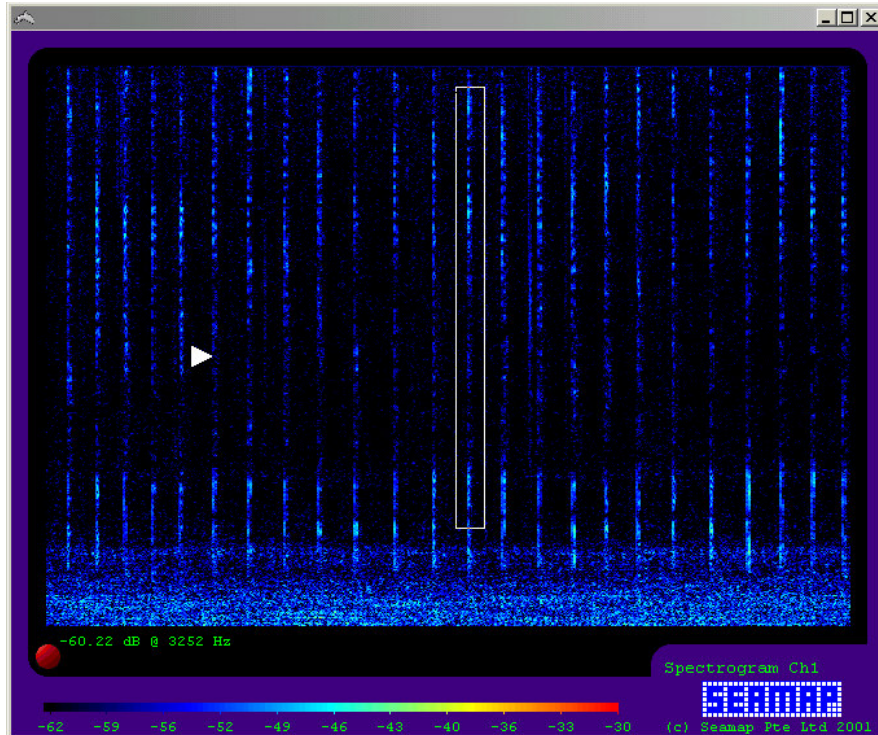

Fig 5.5 Sperm Whale Clicks with a rubber band area selected by the operator

The display below shows the selected data nugget after being processed by the system. The two colorful displays on the left show the spectrogram of the two channels for the rubber-banded area selected. The data is band pass filtered to remove energy above and below the frequencies of interest. The two central displays show the two channels in the time domain after they have been band pass filtered. The top right display shows the correlation function for these two channels giving a sharp peak when there is a best fit from these two channels. This sharp peak corresponds to the two potential incident angles for the energy. The display in the bottom right shows some statistics for the data including estimated range based upon a spherical divergence model (requires some knowledge of source amplitude) as well as the calculated bearing to the signal and some information concerning peak energy and peak frequency of the received energy.

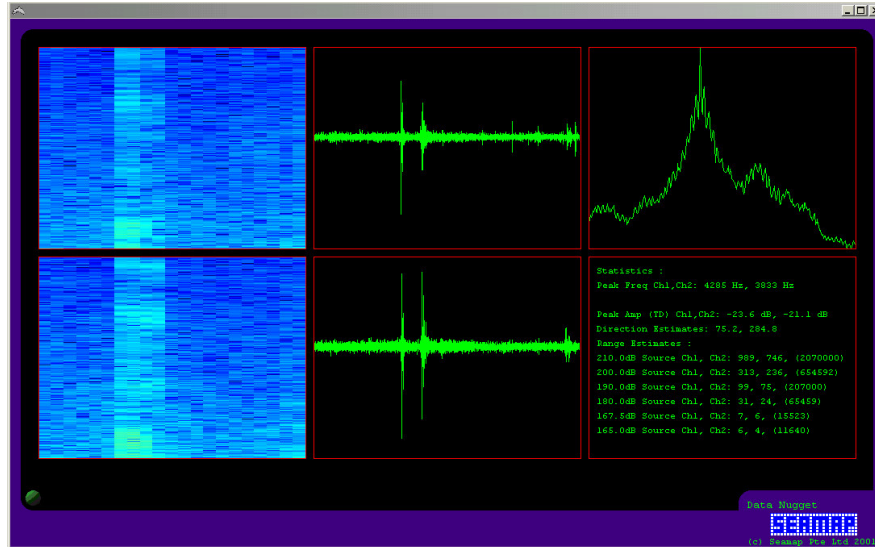

Fig 5.6 Selected area post processed

5.4 Scope Tool

The scope tool is a real-time display of the data arriving in the system. This can be used to provide system QC providing the operator the ability to monitor gain settings, polarity and the electrical integrity of the system.

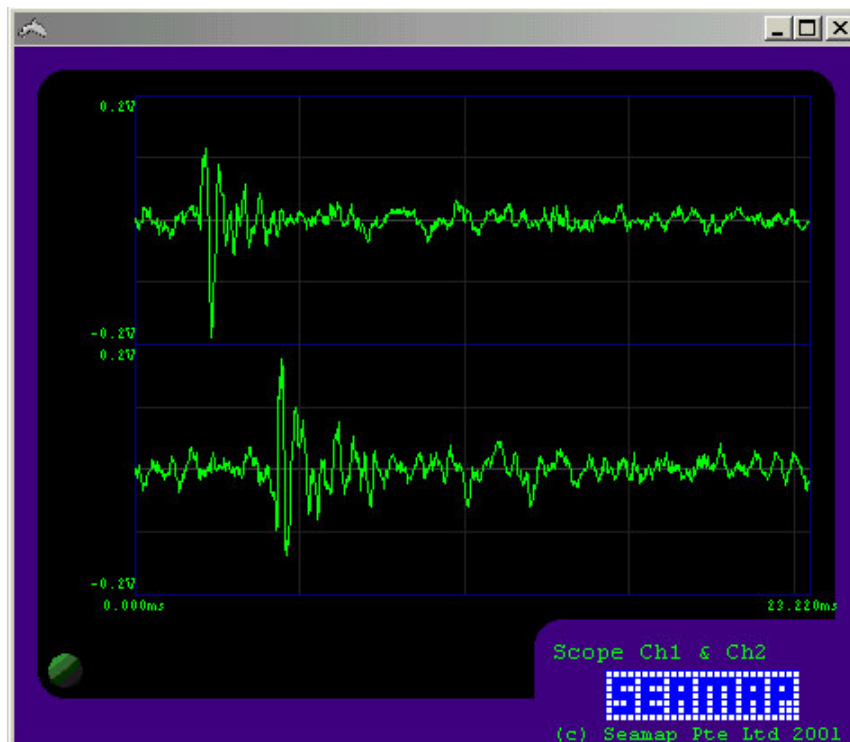

Fig 5.7 Scope Tool

5.5 Map Viewer Application

The map viewer application interfaces to the system database that provides information about detections as well as current vessel position. When detections are added to the database by the main application the map viewer displays them for the operator to see. In the below example it is possible that the operator has entered three detections into the system over the course of time; each detection is displayed as a red square on this display. The two possible bearings from each detection, because of the dipole port and starboard ambiguity, are plotted on the display as two green lines emanating from the detection point. It is clear that with these three lines that there is already a convergence near the top right of the display – the point where all three lines meet. By placing the cursor onto this point on the map that latitude and longitude of the position is displayed, or clicking on the vessel and dragging the mouse pointer to the point of the convergence will display the range and bearing from vessel to the contact.

The software also allows for the operator to pan, zoom and rotate the map viewer as desired. The map viewer will automatically snap to the latest detection – this eliminates unnecessary operator intervention.

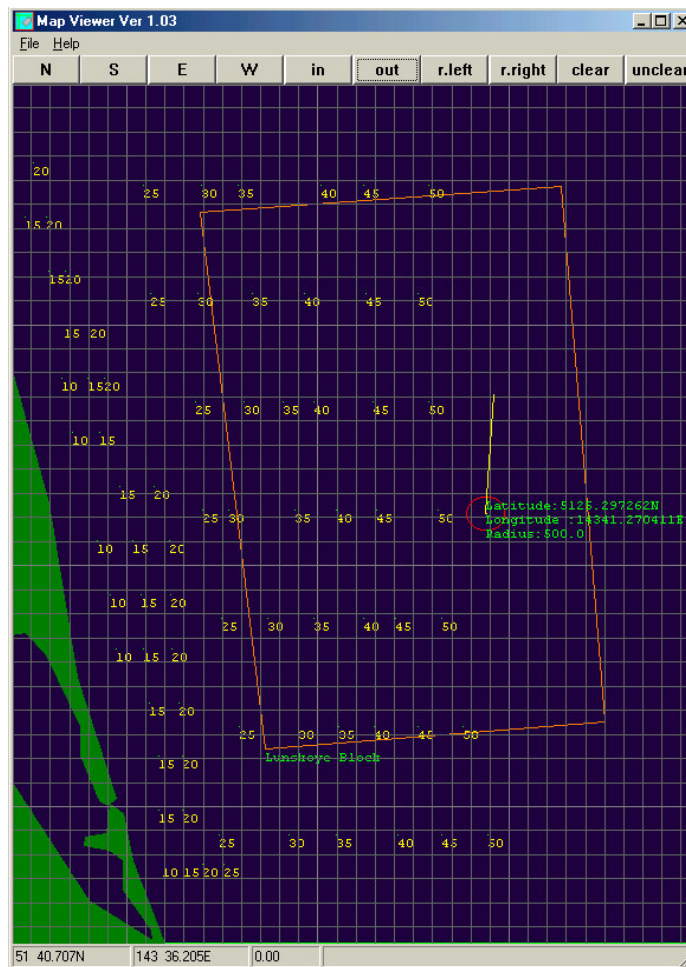

Fig 5.8 Map Viewer

6. Cetacean Monitoring Hardware



Fig 6.1 Display and Streamer Interface Unit



Fig 6.2 Recording Unit



Fig 6.3 Streamer Deployment

7. Specifications

Hydrophone	
Sensitivity	-201 dBV re 1μPa \pm 1dB
Frequency response	1Hz to more than 25KHz (1Hz–15KHz spectrally flat \pm 1.5dB
Preamplifier	Fixed Gain @ 27.32dB, Differential, \pm 24v + Gnd Supply
Streamer	
Channels	4 per active
Length	56m (Long Configuration)
Dimension	63.5mm OD, 4mm skin thickness
Material	Isopar[®] M oil-filled and Polyurethane skin
Lead-in	
Length	330m standard :- Custom sizes available, 60m deck cable
Construction	23mm OD, twin outer stress sheath, shielded, twisted pair, Central
	Kevlar stress member, water blocked, hairy fairing overbraid
Streamer Interface unit	
Channels	4 per unit
Gain	Selectable from x16, x8, x4, x2, x1, x1/2, x1/4, x1/8, x1/16
Recording Computer	
OS	Windows 2000[®]
Spec	2 x 1GHz PIII Processors, 1GByte RAM
Recording Media	CD-R & CD-RW, wav file and proprietary format
Software	Seamap CMS Software version 1.56, multi-threaded Win32 application
	Database Map Viewer, network application
Sampling	Up to 16 Channels at 100KHz 24-bit

8. Appendices

8.1 Cetacean Monitoring System FAQ

Q. How does it work?

Seamap's passive acoustic system detects marine mammals by listening to and detecting the vocalizations. Marine mammals use sounds to echolocate prey, navigate and for social communications. The in-sea listening devices are broadband hydrophone deployed behind a vessel.

Q. How do you know what type of marine mammal you have detected?

Marine mammals emit several different types of vocalisations described colourfully as clicks, whistles, grunts & moans. Different species produce, in general, different sound patterns. The system can detect all vocalisations that lie within its frequency range. These vocalizations are presented to the operator who can classify and identify the marine mammal species.

Q. How do you know the position of the whale?

The system works by taking repeated bearings to a whale vocalisation from the towed hydrophone array to the whale. Knowing the position and azimuth of the towed array allows us to triangulate those bearings to determine the position of the whale.

Q. How far away can you detect a whale?

A short question that unfortunately has a long answer. The first criteria is that the whale vocalisation must be higher than the background noise – this means that the background noise level is a critical factor to determining the threshold of detection. Sound decays over distance in water by varying factors, but a good rule of thumb is the 1/r rule which says the sound amplitude halves for every doubling of distance. i.e. the sound measured at 2m is half what you would measure at 1m, at 4m it halves again, at 8m it halves again, 16m it halves again and so on. In the dB domain of acoustic measurements this corresponds to having 6dB less every time you double the distance.

This is of course a rule of thumb. Reality, however, is clouded with many caveats, One is the frequency of the vocalisation – high frequencies are absorbed more than low frequencies so decay faster. The 1/r spherical divergence is also dependant on water depth and even the seabed composition contribute greatly to the equation. The long and the short of all this is that the further away you are from the whale the quieter it sounds. Eventually it is so quiet that the sound is no longer louder than the background, at this stage we won't be able to detect and direction find the animals vocalization.

Experience shows that with a reasonably quiet platform to tow from, we can detect the louder whale vocalizations – for example sperm whales, at ranges exceeding 6km. Smaller whales with higher frequency vocalizations, such as dolphins, can be detected at ranges of around 2km.

Q. Using only a handful of hydrophones, how can you work out the direction of the animal?

By measuring the time of arrival from one hydrophone to another, and by knowing the speed of sound in water, and the distance between the phones, the incident angle of the sound can be deduced. Using the signal from one phone as a reference and correlating that reference to the signal from the next phone it is possible to discover the time of arrival delay from one phone to the next. The resulting correlation function will contain a peak indicating the time at which the signals matched best. This determines the time of arrival delay.

Q. But what about the depth of the whale?

The direction determined by correlation with a dipole (pair of hydrophones) assumes the vocalizing whale lies in the same plane as the streamer. Unfortunately, reality is rarely this simple. Often the whale is relatively deep compared to the streamer, at other times the whale is close to the surface. This will have an impact on the former assumption. When we create a bearing to a whale we are actually determining a conic surface on which the whale lies. Taking a second bearing defining another conic surface it is possible to determine a three dimensional line on which the whale lies. The third bearing determines a point along that line at which the whale may be. The 2D simplified model that we are using generates an approximation to this conic model, and as long as the range to the animal is significant compared to the depth (i.e. we aren't right on top of the whale) then the errors in this approximation will be small.

8.2 Passive Acoustic Survey Activity List

- Aug '03 – Sep '03** *Sakhalin Russia*
M/V Orient Explorer, DMNG/ PGS, Sakhalin Energy/ Shell
Grey whales were of specific interest however mitigation was for all large whales.
- Jul '03** *Lamont Doherty Earth Observatory (Columbia University),*
R/V Maurice Ewing
The system was used for mitigation during research programmes in the US
- Jun '03** *IAGC, SWSS 2003 (Sperm Whale Seismic Study)*
M/V Kondor Explorer
Gulf of Mexico
The system was used to monitor and mitigate Sperm whale activity in the Gulf of Mexico
- Jun '03** *Woods Hole Oceanographic Institute, SWSS 2003*
M/V Maurice Ewing
Gulf of Mexico
The system was used to locate, monitor and track sperm whales for research into whale behaviour
- Apr '03** *Canada, Novascotia, Halifax*
M/V Geco Triton, Western Geco, EnCana,
800m mitigation zone applied, Species of interest were the Northern Bottleneck whale and Blue whale
- Dec '02** *Australia, Bass Straits, Victoria*
M/V Total Voyager, chase vessel for Western Monarch, Western Geco
A mitigation zone of 300m was applied. The survey was carried out in an area that is normally restricted. The species of specific interest was the Blue whale.
- Jun '02** *Passive Acoustic Industry Trial*
M/V Rylan T, SWSS 2002, IAGC
The system was used to detect and track Sperm whales.

8.3 Record of Acoustic Detection

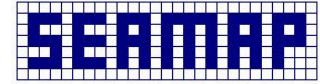

MARINE MAMMAL RECORD OF ACOUSTIC DETECTION (Vessel)

Date <DD/MM/YY>	Time < HH:MM >	Sighting Reference < NNN >
Acoustic File (.wav) < Grabbit-DDMMYY-HHMMSS.00.wav >		
Vessel < Vessel Name >	Observer < Name of observer >	
Vessel's Position (Lat. and Long.)	Water depth (metres)	
Acoustic indication of type of Species	Visual Observation Yes <input type="checkbox"/> No <input type="checkbox"/>	
Total number	Number of adults Number of juveniles	
Weather: - Wind Direction – Wind (Beaufort) - Sea State - Visibility -		Photograph or video taken Yes <input type="checkbox"/> No <input type="checkbox"/>
Behaviour/Comments		Direction of travel of Mammals in relation to vessel
Activity of vessel		Direction of travel of Mammals
		Closest Correlated distance of Mammals from vessel (metres)

8.1 Industry Guidelines

OMB Control Number: 1010-0154
OMB Expiration Date: September 30, 2003

**UNITED STATES DEPARTMENT OF THE INTERIOR
MINERALS MANAGEMENT SERVICE
GULF OF MEXICO OCS REGION**

NTL No. 2003-G08

Effective Date: June 5, 2003

**NOTICE TO LESSEES AND OPERATORS OF FEDERAL OIL, GAS, AND
SULPHUR LEASES IN THE OUTER CONTINENTAL SHELF,
GULF OF MEXICO OCS REGION**

**Implementation of Seismic Survey Mitigation Measures and
Protected Species Observer Program**

The Minerals Management Service (MMS) is issuing this Notice to Lessees and Operators (NTL), pursuant to 30 CFR 250.103, to explain how you implement seismic survey mitigation measures, including special ramp-up procedures and protected species observation and reporting. This NTL supersedes and replaces NTL No. 2002-G07, effective August 22, 2002, and NTL No. 2002-G07 (Addendum 1), effective October 15, 2002, on this subject. This NTL applies to all seismic operations throughout the Gulf of Mexico OCS in waters greater than 200 m (656 ft) in depth. The measures contained herein apply to all on-lease seismic surveys you conduct under 30 CFR 250.201 and all off-lease seismic surveys you conduct under 30 CFR 251.

Background

The use of an airgun or airgun arrays while conducting seismic operations may have an impact on marine wildlife, including marine mammals and sea turtles. Some marine mammals, such as the sperm whale (*Physeter macrocephalus*), and all sea turtles that inhabit the Gulf of Mexico are protected under the Endangered Species Act (ESA). All marine mammals are protected under the Marine Mammal Protection Act (MMPA).

In July 2002, the MMS completed a formal Section 7 consultation under the ESA with the National Oceanic and Atmospheric Administration Fisheries Service (NOAA Fisheries) on lease sale activities.

The NOAA Fisheries issued new mitigation measures in a Biological Opinion (BiO) for Gulf of Mexico (GOM) Outer Continental Shelf (OCS) Lease Sale 184. The BiO specifically requires seismic operators to use ramp-up and visual observation procedures for seismic acquisition operations in water depths equal to or greater than 200 meters (656 feet). Ramp-up procedures are already in use on seismic vessels in the GOM. The MMS also conducted a formal Section 7 consultation under the ESA with NOAA Fisheries for GOM OCS Lease Sale 185 as well as the remainder of the lease sales to be held in the Central and Western Gulf of Mexico Planning Areas included in the Five-Year Oil and Gas Leasing Program for 2002-2007. NOAA Fisheries also issued a BiO for this Multi-Lease Sale consultation. The Multi-Lease Sale BiO contained Conservation Recommendations for the protection of marine mammals and sea turtles during seismic operations. Consistent with the mitigation measures for ramp-up, visual observation and reporting, and with these Conservation Recommendations, the MMS is issuing this NTL.

Procedures for ramp-up, protected species observer training, visual monitoring and reporting are described in detail in this NTL. Performance of these mitigation measures will be a condition of approval of applications for geophysical permits, and will be applicable to geophysical activities conducted under lease terms for all seismic survey operations conducted in waters deeper than 200 meters (656 feet) throughout the GOM. You must demonstrate your compliance with these conditions by submitting to MMS certain reports detailed in this NTL.

Definitions

Terms used in this NTL have the following meanings:

1. Airgun means a device that releases compressed air into the water column, creating an acoustical energy pulse with the purpose of penetrating the seafloor.
2. Ramp-up means the gradual increase in emitted sound levels from an airgun array by systematically turning on the full complement of an array of airguns over a period of time.
3. Visual monitoring means the use of trained observers to scan the ocean surface visually for the presence of marine mammals and sea turtles. These observers must have successfully completed a visual observer training program as described below. The area to be scanned visually includes, but is not limited to, the exclusion zone. Visual monitoring of an exclusion zone and adjacent waters is intended to establish and, when visual conditions allow, maintain a zone around the sound source and seismic vessel that is clear of marine mammals and sea turtles, thereby reducing or eliminating the potential for injury.
4. Exclusion zone means the area at and below the sea surface within a radius of 500 meters surrounding the center of an airgun array and the area within the immediate vicinity of the survey vessel.

Ramp-up Procedures

The intent of ramp-up is to warn animals of pending seismic operations and to allow sufficient time for those animals to leave the immediate vicinity. Under normal conditions, animals sensitive to these activities are expected to move out of the area. For all seismic surveys, use the ramp-up procedures described below to allow sperm whales, other marine mammals, and sea turtles to depart the exclusion zone before seismic surveying begins.

Measures to conduct ramp-up procedures during all seismic survey operations are as follows:

1. Visually monitor the exclusion zone and adjacent waters for the absence of sperm whales for at least 30 minutes before initiating ramp-up procedures. If no sperm whales are detected, you may initiate ramp-up procedures. Do not initiate ramp-up procedures at night or when you cannot visually monitor the exclusion zone for sperm whales if your minimum source level drops below 160 dB re 1 mPa-m (rms) (see measure 5).
2. Initiate ramp-up procedures by firing a single airgun. The preferred airgun to begin with should be the smallest airgun, in terms of energy output (dB) and volume (in³).
3. Continue ramp-up by gradually activating additional airguns over a period of at least 20 minutes, but no longer than 40 minutes, until the desired operating level of the airgun array is obtained.
4. Immediately shut down all airguns ceasing seismic operations at any time a sperm whale is detected entering or within the exclusion zone. You may recommence seismic operations and ramp-up of airguns only when the exclusion zone has been visually inspected for at least 30 minutes to ensure the absence of sperm whales.
5. You may reduce the source level of the airgun array to maintain a minimum source level of 160 dB re 1 mPa-m (rms) for routine activities, such as making a turn between line transects, or for maintenance needs. This procedure may be conducted during periods of impaired visibility (e.g., darkness, fog, high sea states) and does not require a 30-minute visual clearance of the exclusion zone before the airgun array is again ramped up to full output.

Protected Species Observer Program

Visual Observers

Visual observers who have completed a protected species observer training program as described below will be required on all seismic vessels conducting operations in water depths greater than 200 meters (656 ft) throughout the Gulf of Mexico by August 31, 2003. At least two protected species observers will be required on watch aboard seismic vessels at all times during daylight hours (dawn to

dusk) when seismic operations are being conducted, unless conditions (fog, rain, darkness) make sea surface observations impossible. If conditions deteriorate during daylight hours such that the sea surface observations are halted, visual observations must resume as soon as conditions permit. Operators may engage trained third party observers, may utilize crew members after training, as observers, or may use a combination of both third party and crew observers. During these observations, the following guidelines shall be followed: (1) other than brief alerts to bridge personnel of maritime hazards, no additional duties may be assigned to the observer during his/her visual observation watch (if conditions warrant more vigilant look-outs when navigating around or near maritime hazards, additional personnel must be used to ensure that watching for protected species remains the primary focus of the on-watch observers), (2) no observer will be allowed more than 4 consecutive hours on watch as a visual observer, (3) a •reck•time of no less than 2 hours must be allowed before an observer begins another visual monitoring watch rotation (break time means no assigned observational duties), and (4) no person (crew or third party) on watch as a visual observer will be assigned a combined watch schedule of more than 12 hours in a 24-hour period. Due to the concentration and diligence required during visual observation watches, operators who choose to use trained crew members in these positions are encouraged to select only those crew members who demonstrate willingness as well as ability to perform these duties.

Training

All visual observers must have completed a protected species observer training course. The MMS will not sanction particular trainers or training programs. However, basic training criteria have been established and must be adhered to by any entity that offers observer training. Operators may utilize observers trained by third parties, may send crew for training conducted by third parties, or may develop their own training program. All training programs offering to fulfill the observer training requirement must (1) furnish to the MMS, at the address listed in this NTL, a course information packet that includes the name and qualifications (i.e., experience, training completed, or educational background) of the instructor(s), the course outline or syllabus, and course reference material; (2) furnish each trainee with a document stating successful completion of the course; and (3) provide the MMS with names, affiliations, and dates of course completion of trainees.

(Paperwork Reduction Act: Please note that the information collection requirements for fulfilling observer training programs posed above have not yet been approved by OMB. Specifically, you are not obliged to furnish the MMS and/or the trainees the information specified in (1), (2), and (3) above until OMB approves and assigns a new approval expiration date on the first page of this NTL. Note that the training course criteria below have been approved by OMB and those requirements must be met.)

The training course must include the following elements:

- I. Brief overview of the MMPA and the ESA as they relate to seismic acquisition and protection of marine mammals and sea turtles in the Gulf of Mexico
- II. Brief overview of seismic acquisition operations in the Gulf of Mexico
- III. Overview of seismic mitigation measures (NTLs) and the protected species observer program in the Gulf of Mexico
- IV. Discussion of the role and responsibilities of the protected species observer in the Gulf of Mexico, including:
 - a. Legal requirements (why you are here and what you do)
 - b. Professional behavior (code of conduct)
 - c. Integrity

- d. Authority of protected species observer to call for shut-down of seismic acquisition operations
 - e. Assigned duties
 - 1. What can be asked of the observer
 - 2. What cannot be asked of the observer
 - f. Reporting of violations and coercion
- V. Identification of Gulf of Mexico marine mammals and sea turtles, with emphasis on sperm whales
- VI. Cues and search methods for locating marine mammals, especially sperm whales, and sea turtles.
- VII. Data collection and reporting requirements:
- a. Forms and reports to MMS via email protectedspecies@mms.gov on the 1st and 15th of each month
 - b. Sperm whale in exclusion zone/shut-down report within 24 hours

Methods

The observers on duty will look for sperm whales, other marine mammals, and sea turtles using the naked eye and hand-held binoculars provided by the seismic vessel operator. The observers will stand watch in a suitable location that will not interfere with navigation or operation of the vessel and that affords the observers an optimal view of the sea surface. The observers will provide 360° coverage surrounding the seismic vessel and will adjust their positions appropriately to ensure adequate coverage of the entire area. These observations must be consistent, diligent, and free of distractions for the duration of the watch.

Visual monitoring will begin no less than 30 minutes prior to the beginning of ramp-up and continue until seismic operations cease or sighting conditions do not allow observation of the sea surface (e.g., fog, rain, darkness). If a sperm whale(s) is observed, the observer should note and monitor the position (including lat./long. of vessel and relative bearing and estimated distance to whale) until the whale dives or moves out of visual range of the observer. Make sure you continue to observe for additional sperm whales that may surface in the area, as often there are numerous animals that may surface at varying time intervals. At any time a sperm whale is observed within an estimated 500 meters (1,614 feet) of the sound source array (exclusion zone, whether due to the whale's movement, the vessel's movement, or because the whale surfaced inside the exclusion zone, the observer will call for the immediate shut-down of the seismic operation and airgun firing (the vessel may continue on its course but all airgun discharges must cease). The vessel operator must comply immediately with such a call by an on-watch visual observer. Any disagreement or discussion should occur only after shut-down. When no sperm whales are sighted for at least a 30-minute period, ramp-up of the source array may begin. Ramp-up cannot begin unless conditions allow the sea surface to be visually inspected for sperm whales for 30 minutes prior to commencement of ramp-up (unless the method described in the section entitled experimental Passive Acoustic Monitoring is used). Thus, ramp-up cannot begin after dark or in conditions that prohibit visual inspection (fog, rain, etc.) of the exclusion zone. Any shut-down due to a sperm whale(s) sighting within the exclusion zone must be followed by a 30-minute all-clear period and then a standard, full ramp-up. Any shut-down for other reasons, including, but not limited to, mechanical or electronic failure, resulting in the cessation of the sound source for a period greater than 20 minutes, must also be followed by full ramp-up procedures. In recognition of occasional, short periods of the cessation of airgun firing for a variety of reasons, periods of airgun silence **not exceeding 20 minutes** in duration will not require ramp-up for the

resumption of seismic operations if: (1) visual surveys are continued diligently throughout the silent period (requiring daylight and reasonable sighting conditions), and (2) no sperm whales, other marine mammals, or sea turtles are observed in the exclusion zone. If sperm whales, other marine mammals, or sea turtles are observed in the exclusion zone during the short silent period, resumption of seismic survey operations must be preceded by ramp-up.

Reporting

The importance of accurate and complete reporting of the results of the mitigation measures cannot be overstated. Only through diligent and careful reporting can the MMS, and subsequently NOAA Fisheries, determine the need for and effectiveness of mitigation measures. Information on observer effort and seismic operations are as important as animal sighting and behavior data. In order to accommodate various vessels' bridge practices and preferences, vessel operators and observers may design data reporting forms in whatever format they deem convenient and appropriate. Alternatively, observers or vessel operators may adopt the United Kingdom's Joint Nature Conservation Committee forms (available at their website www.jncc.gov.uk). At a minimum, the following items should be recorded and included in reports to the MMS:

Observer Effort Report: Prepared for each day during which seismic acquisition operations are conducted. Furnish an observer effort report to MMS on the 1st and the 15th of each month that includes:

- Vessel name
- Observers' names and affiliations
- Survey type (e.g., site, 3D, 4D)
- MMS Permit Number (for off-lease seismic surveys) or OCS Lease Number (for on-lease seismic surveys)
- Date
- Time and lat./long. when daily visual survey began
- Time and lat./long. when daily visual survey ended
- Average environmental conditions while on visual survey, including
 - Wind speed and direction
 - Sea state (glassy, slight, choppy, rough or Beaufort scale)
 - Swell (low, medium, high or swell height in meters)
 - Overall visibility (poor, moderate, good)

Survey Report: Prepared for each day during which seismic acquisition operations are conducted and the airguns are being discharged. Furnish a survey report to MMS on the 1st and the 15th of each month during which operations are being conducted that includes

- Vessel name
- Survey type (e.g., site, 3D, 4D)
- MMS Permit Number (for off-lease seismic surveys) or OCS Lease Number (for on-lease seismic surveys)
- Date
- Time pre-ramp-up survey begins

- Were sperm whales seen during pre-ramp-up survey?
- Time ramp-up begins
- Were sperm whales seen during ramp-up?
- Time airgun array is operating at the desired intensity
- Were sperm whales seen during survey?
- If sperm whales were seen, was any action taken (i.e., survey delayed, guns shut down)?
- Reason that sperm whales might not have been seen (e.g., swell, glare, fog)
- Time airgun array stops firing

Sighting Report: Prepared for each sighting of a marine mammal or sea turtle made during seismic acquisition operations. Furnish a sighting report to MMS on the 1st and the 15th of each month during which operations are being conducted that includes

- Vessel name
- Survey type (e.g., site, 3D, 4D)
- MMS Permit Number (for off-lease seismic surveys) or OCS Lease Number (for on-lease seismic surveys)
- Date
- Time
- Watch status (Were you on watch or was this sighting made opportunistically by you or someone else?)
- Observer or person who made the sighting
- Lat. / long. of vessel
- Bearing of vessel
- Bearing and estimated range to animal(s) at first sighting
- Water depth (meters)
- Species (or identification to lowest possible taxonomic level)
- Certainty of identification (sure, most likely, best guess)
- Total number of animals
- Number of juveniles
- Description (as many distinguishing features as possible of each individual seen, including length, shape, color and pattern, scars or marks, shape and size of dorsal fin, shape of head, and blow characteristics)
- Direction of animals travel •compass direction
- Direction of animals travel •related to the vessel (drawing preferably)
- Behavior (as explicit and detailed as possible; note any observed changes in behavior)
- Activity of vessel

- Airguns firing? (yes or no)
- Closest distance (meters) to animals from center of airgun or airgun array (whether firing or not)

Note: If this sighting was of a sperm whale(s) within the exclusion zone that resulted in a shut-down of the airguns, include in the sighting report the observed behavior of the whale(s) before shut-down, the observed behavior following shut-down (specifically noting any change in behavior), and the length of time between shut-down and subsequent ramp-up to resume the seismic survey (note if seismic survey was not resumed as soon as possible following shut-down). Send this report to MMS **within 24 hours of the shut-down**. These sightings should also be included in the first regular semi-monthly report following the incident.

Additional information, important points, and comments are encouraged. All reports will be submitted to MMS on the 1st and the 15th of each month (with one exception noted above). Forms should be scanned (or data typed) and sent via email to protectedspecies@mms.gov.

Please note that these marine mammal and sea turtle reports are in addition to any reports you submit under NTL No. 98-20, dated September 15, 1998, and NTL No. 2002-G01, effective March 15, 2002, and reports required as a condition of your geophysical permit.

Borehole Seismic Surveys

Borehole seismic surveys differ from surface seismic surveys in a number of ways including the use of much smaller airgun arrays, having an average survey time of 12-24 hours, utilizing a sound source that is not usually moving at 4-5 knots, and requiring the capability of moving the receiver in the borehole between shots. Due to these differences, the following altered mitigations apply only to borehole seismic surveys:

- During daylight hours, when visual observations of the exclusion zone are being performed as required in this NTL, borehole seismic operations will not be required to ramp-up for shutdowns of 30 minutes or less in duration, as long as no sperm whales, other marine mammals, or sea turtles are observed in the exclusion zone during the shutdown. If a sperm whale, other marine mammal, or sea turtle is sighted in the exclusion zone, ramp-up is required and may begin only after visual surveys confirm that the exclusion zone has been clear for 30 minutes.
- During nighttime or when conditions prohibit visual observation of the exclusion zone, ramp-up will not be required for shutdowns of 20 minutes or less in duration. For borehole seismic surveys that utilize passive acoustics during nighttime and periods of poor visibility, ramp-up is not required for shutdowns of 30 minutes or less.
- Nighttime or poor visibility ramp-up is allowed only when passive acoustics are used to ensure that no sperm whales are present in the exclusion zone (as for all other seismic surveys). Operators are strongly encouraged to acquire the survey in daylight hours when possible.
- Protected species observers must be used during daylight hours, as required in this NTL, and may be stationed either on the source boat or on the associated drilling rig or platform if a clear view of the sea surface in the exclusion zone and adjacent waters is available.
- All other mitigations and provisions for seismic surveys as set forth in this NTL will apply to borehole seismic surveys.
- Reports should reference OCS Lease Number, Area/Block and Borehole Number

Experimental Passive Acoustic Monitoring

Sperm whales are very vocal marine mammals, and periods of silence are usually short and most often occur when these animals are at the surface and may be detected using visual observers.

However, sperm whales are at the greatest risk of potential injury from seismic airguns when they are submerged and under the airgun array. Passive acoustic monitoring appears to be very effective at detecting submerged and diving sperm whales when they are not detectable by visual observation. The MMS strongly encourages operators to participate in an experimental program by including passive acoustic monitoring as part of the protected species observer program. Inclusion of passive acoustic monitoring does **not** relieve an operator of any of the mitigations (including visual observations) in this NTL **with the following exception**: Monitoring for sperm whales with a passive acoustic array by an observer proficient in its use will allow ramp-up and the subsequent start of a seismic survey during times of reduced visibility (darkness, fog, rain, etc.) when such ramp-up otherwise would not be permitted using only visual observers. If you use passive acoustic monitoring, include an assessment of the usefulness, effectiveness, and problems encountered with the use of that method of marine mammal detection in the reports described in this NTL. A description of the passive acoustic system, the software used, and the monitoring plan should also be reported to MMS at the beginning of its use.

(Paperwork Reduction Act: Please note that the information collection requirements for using passive acoustic monitoring posed above have not yet been approved by OMB. Specifically, you are not obliged to submit a description of the passive acoustic system, the software used, and the monitoring plan to MMS until OMB approves and assigns a new approval expiration date on the first page of this NTL. Note that all other report requirements on the passive acoustic system have been approved by OMB and must be met.)

Paperwork Reduction Act of 1995 (PRA) Statement

The PRA (44 U.S.C. Chapter 35) requires us to inform you that we collect the information described in this NTL to ensure that you conduct operations in a manner that will not jeopardize threatened or endangered species or destroy or adversely modify critical habitat that has been designated for those species. We protect all proprietary information submitted according to the Freedom of Information Act and 30 CFR 250.196. An agency may not conduct or sponsor a collection of information unless it displays a currently valid Office of Management and Budget (OMB) control number. You are not obligated to respond until the OMB has approved this collection of information. We estimate the hour burden for providing the information to be 1 hour per report. Direct comments regarding the burden or any other aspect of this information collection to the Information Collection Clearance Officer, Mail Stop 4230, Minerals Management Service, 1849 C Street, N.W., Washington, DC 20240.

In addition, this NTL refers to information collection requirements under 30 CFR 250, subpart B. The OMB has approved all of the information collection requirements in these regulations and assigned OMB control number 1010-0049.

Contact

Any questions regarding this NTL should be submitted in writing to: protectedspecies@mms.gov. Submittals by mail may be directed to:

Minerals Management Service
Gulf of Mexico OCS Region
Attention: Environmental Sciences Unit (MS 5430)
1201 Elmwood Park Blvd.
New Orleans, LA 70123-2394

Chris C. Oynes
Regional Director

Marine Mammals Updates

Industry Responds to U.S. NOAA Fisheries on Next Round in EGOM Biological Opinion

IAGC worked with other industry associations during July 2003 to respond to NOAA Fisheries on the agency's July 2003 comments to industry's June critique of the draft NOAA Fisheries Biological Opinion on the Eastern Gulf of Mexico. As reported in the June 2003 IAGC Newsletter, the IAGC and other members of the industry coalition filed comments with the Minerals Management Service and NOAA Fisheries that expressed our concerns with the draft Biological Opinion for Eastern Gulf of Mexico Lease Sales. Follow-up meetings were also held with both agencies in which we expressed our ongoing concerns with elements and conclusions of the Opinion.

NOAA Fisheries' July response indicates that they reviewed industry's comments thoroughly and are committed to revising the Biological Opinion significantly. In our most recent correspondence to the agency, we expressed our appreciation for its serious consideration of our concerns and commitment to improvements in the Biological Opinion. Phil Fontana of Veritas, Chair of the Industry's Research/Science Subcommittee, provided the majority of the industry's comments. While the exact treatment of the debatable sections will not be known until industry has an opportunity to review the next draft Opinion (expected in August), we are pleased that NOAA Fisheries appears to be re-thinking some of its conclusions. The final Biological Opinion is expected to be delivered to the MMS in early September. (Sims)

U.S. Marine Mammal Legislation and Issues Considered by Congressional Committees

Key Committees in both the House of Representatives and the Senate held hearings in July to evaluate legislation to reauthorize the Marine Mammal Protection Act. The House Subcommittee on Fisheries, Wildlife and Oceans of the Resources Committee held a "mark-up" hearing on July 24 to consider H.R. 2693, the "Marine Mammal Protection Act Amendments of 2003". The bill would reauthorize the MMPA and make several important changes to it. Specifically, it would amend the definition of "harassment" under the Act to limit Level A harassment to an activity that "has the probability to injure a marine mammal..." and Level B harassment to an activity that "has the potential to disturb a marine mammal...by causing biologically significant disruption of activities..." The definitions of harassment under current law allow even minimal behavioral changes to be considered "harassment". The Subcommittee is expected to continue its consideration of this legislation in September when it returns from its August recess.

In the Senate, the Oceans, Fisheries and Coast Guard Subcommittee held an "oversight" hearing on July 16 in which it heard testimony on a broad range of issues surrounding the reauthorization of MMPA and the current state of marine mammals. While not focused on a particular legislative proposal, the Subcommittee received testimony from NOAA, U.S. Fish and Wildlife, the Navy, the Marine Mammal Commission, and several conservation and research organizations. The Senate is expected to continue its deliberations later this year as well, though at a slower pace than the House. (Sims)

[Back](#)

U.S. NOAA Fisheries to Consider New Acoustic Threshold Criteria

IAGC continues to follow efforts at NOAA Fisheries to establish new Acoustic Threshold Criteria for marine mammals, including the Sperm Whale. The agency has been working for some time with a panel of respected scientists to establish new standards for acoustic levels that are believed to disturb marine mammals and/or produce hearing threshold shifts. The current standards utilized by NOAA Fisheries for marine mammals are at 160 dB for MMPA "Level B Harassment" (those that disturb sperm whale behaviors) and 180 dB for "Level A Harassment" (those that cause temporary or permanent hearing impairment or other physical injury). These criteria were established in 1997 at a HESS workshop at Pepperdine University based on the scientific understanding of marine mammal

hearing sensitivities at the time. The current effort is reviewing these criteria in the context of the improved understanding of marine mammal reactions to noise and, are expected to establish new thresholds that would be used in the regulation of marine activities, including geophysical operations. The new criteria, when complete, are expected to be the basis on which future regulatory actions are taken. We continue to advocate speedy adoption of these new criteria. (Sims)

Clarification: New NTL on Seismic Mitigation Measures and Observer Program

A meeting of the Americas offshore committee was held to discuss the new NTL 2003-G08 on "Implementation of Seismic Survey Mitigation Measures and Protected Species Observer program". The meeting started discussion on "Actual Peak Outputs From Air Guns", this prompted discussion from the High Resolution companies as they are using single 60 cu ins air guns. The conclusion was that any air gun source would have an output of >1 bar m and therefore would be higher than the 180dB mentioned in the NTL.

A few points from the NTL were highlighted and clarified:

1) Ramp up is not allowed if any marine mammal or turtle is within the exclusion zone; however, once the guns are operating, they will only be shut down for sperm whales within the exclusion zone.

2) Two trained observers are required to be on active watch during all daylight operations. Each observer can be on watch for only 4 hours at a time then must take a break. This means that a minimum of 3 trained and certified individuals will be needed for seismic operations.

3) [Passive acoustic monitoring is encouraged for both borehole & surface seismic operations. "Monitoring for sperm whales with a passive acoustic array by an observer proficient in its use will allow ramp-up and the subsequent start of a seismic survey during times of reduced visibility \(darkness, fog, rain, etc.\) when such ramp-up otherwise would not be permitted using only visual observers. If you use passive acoustic monitoring, include an assessment of the usefulness, effectiveness, and problems encountered with the use of that method of marine mammal detection in the reports described in this NTL. A description of the passive acoustic system, the software used, and the monitoring plan should also be reported to MMS at the beginning of its use."](#)

4) [No ramp up is required after a shutdown of less than 20 minutes \(30 minutes if passive acoustics is being used\), providing there is not any marine mammals or turtles within the exclusion zone.](#)

It was brought up, by some members, that the impact of increasing the crews on the High Resolution vessels and/or borehole seismic crews by 3 persons increased the liability by an order of magnitude and caused numerous complications with space on vessels/rigs.

Training for visual observers was briefly discussed. The IAGC is intending to act as a clearinghouse for this information, as MMS is unable to recommend trainers due to its procurement process. The criteria for the training are:

"All visual observers must have completed a protected species observer training course. The MMS will not sanction particular trainers or training programs. However, basic training criteria have been established and must be adhered to by any entity that offers observer training. Operators may utilize observers trained by third parties, may send crew for training conducted by third parties, or may develop their own training program. All training programs offering to fulfill the observer training requirement **must** (1) furnish to the MMS, at the address listed in this NTL, a course information packet that includes the name and qualifications (i.e., experience, training completed, or educational background) of the instructor(s), the course outline or syllabus, and course reference material; (2) furnish each trainee with a document stating successful completion of the course; and (3) provide the MMS with names, affiliations, and dates of course completion of trainees."

Companies should ensure that their chosen trainer complies with the training requirements outlined in the NTL (see above).

Visual observers can also be contracted from a number of companies. If you have names of training and contractor services or have the need of such names please contact IAGC at iagc@iagc.org.

A follow up meeting was held with the MMS in New Orleans on July 30th to which a number of Geophysical contractors attended. The MMS gave a brief history of the origin of the NTL and fielded a number of questions asking for clarification on various sections of the NTL.

Clarifications to come out of these discussions:

1. The requirements to post visual observers immediately, which was set out in the NTL No. 2002-G07, effective August 22, 2002, which allowed for untrained crew to serve as visual observers until training requirements were developed, did not go away with the issuance of this new NTL.
2. Visual observer reports must be timely filed with MMS (as outlined in NTL).

Advice: unless you have a contractual agreement with the client stating that they will file reports and take on liability for doing so, file all marine mammal reports yourself, as required in the NTL.
3. MMS will not proactively certify training programs. Advice: Geophysical operator should review the programs of potential training providers to ensure conformance with training elements laid out in the NTL. It is your responsibility to ensure your trainer conforms and provides the MMS with names, affiliations, and dates of course completion of trainees.

Guidelines for minimizing acoustic disturbance to marine mammals from seismic surveys

April 1998 Version

These guidelines are aimed at minimising acoustic disturbance to marine mammals from seismic surveys and other operations where acoustic energy is released. Application of the guidelines is required under license conditions in blocks licensed under the 16th and 17th rounds of offshore licensing. However, member companies of the UK Offshore Operators Association (UKOOA) and the International Association of Geophysical Contractors (IAGC) have indicated that they will comply with these guidelines in all areas of the UK Continental Shelf (UKCS) and in some cases elsewhere. The guidelines apply to all marine mammals, including seals, whales, dolphins and porpoises. All surveys using higher energy seismic sources (including site surveys as well as large scale seismic surveys) should comply with these guidelines.

Precautions to reduce the disturbance caused by seismic surveys

Seismic surveys at sea do not necessarily constitute a threat to marine mammals, if care is taken to avoid situations which could potentially harm the animals.

A. The Planning Stage

When a seismic survey is being planned, operators should:

- Contact the Joint Nature Conservation Committee (JNCC - see Further Information for address) to determine the likelihood that marine mammals will be encountered. In sensitive areas, the JNCC may request precautions in addition to those outlined below (for example, the special conditions attached to some oil and gas licences).
- In areas which are important for marine mammals (as indicated in consultation with the JNCC) operators should seek to provide the most appropriately qualified and experienced personnel to act as marine mammal observers on board the seismic survey vessel. If possible, such observers should be experienced cetacean biologists. As a minimum, it is recommended that observers should have attended an appropriate training course.
- If advised to do so by the JNCC, discuss the precautions which can be taken to reduce disturbance, and the design of any scientific studies with the Sea Mammal Research Unit (see Annex for address). In areas where marine mammals are abundant, properly conducted observation and recordings using qualified observers (see above) carried out before, during and after the seismic survey, can provide valuable information on its effect.
- Operators should plan surveys so that their timing will reduce the likelihood of encounters with marine mammals, although at present there is limited information on their distribution in some areas.
- Operators should seek to reduce and/or baffle unnecessary high frequency noise produced by air-guns or other acoustic energy sources.

B. During the Seismic Survey

When conducting a seismic survey, the following guidelines should be followed:

LOOK AND LISTEN

Beginning at least 30 minutes before commencement of any use of the seismic sources, the operator and observers should carefully make a visual check from a suitable high observation platform to see if there are any marine mammals within 500 metres, using the cues mentioned later in these guidelines to detect the presence of cetaceans. Hydrophones and other listening equipment may provide

additional information on the presence of inconspicuous species, such as harbour porpoises, or submerged animals, and should be used whenever possible.

This will be particularly appropriate in poor weather, when visual evidence of marine mammal presence cannot be obtained.

DELAY

If marine mammals are present, the start of the seismic sources should be delayed until they have moved away, allowing adequate time after the last sighting (at least 20 minutes) for the animals to move well out of range.

Hydrophones may also be useful in determining when cetaceans have moved. In situations where seal(s) are congregating immediately around a platform, it is recommended that commencement of the seismic sources begins at least 500 m from the platform.

THE SLOW BUILD UP

Where equipment allows, power should be built up slowly from a low energy start-up (e.g. starting with the smallest air-gun in the array and gradually adding in others) over at least 20 minutes to give adequate time for marine mammals to leave the vicinity. There should be a soft start every time the air-guns are used, even if no marine mammals have been seen. The soft start may only be waived for surveys where the seismic sources always remain at low power levels e.g. some site surveys.

KEEP IT LOW

Throughout the survey, the lowest practicable power levels should be used.

C. Report after the survey

A report detailing marine mammals sighted (standard forms are available from JNCC), the methods used to detect them, problems encountered, and any other comments will help increase our knowledge and allow us to improve these guidelines. Reports should be sent to the JNCC (see Further Information for address). Reports should include the following information:

- Date and location of survey
- Number and volume of airguns used
- Nature of air-gun discharge frequency (in Hz), intensity (in dB re. 1µPa or bar metres) and firing interval (seconds), or details of other acoustic energy used
- Number and types of vessels involved in the survey
- A record of all occasions when the air-guns were used, including the watch beforehand and the duration of the soft-start (using standard forms)
- Details of any problems encountered during marine mammal detection procedures, or during the survey
- Marine mammal sightings (using standard forms)
- Details of watches made for marine mammals and the seismic activity during watches (using standard forms)
- Reports from any observers on board

Background to the guidelines

These guidelines reflect principles which could be used by anyone planning marine operations that could cause acoustic or physical disturbance to marine mammals. The recommendations contained in the guidelines should assist in ensuring that all marine mammals in areas of proposed seismic survey activity are protected against possible injury, and disturbance is minimised.

The guidelines were originally prepared by a Working Group convened at the request of the Department of the Environment, developed from a draft prepared by the Sea Mammal Research Unit. The guidelines have been reviewed twice by the Joint Nature Conservation Committee following consultation with interested parties and in the light of experience after their use since 1995.

Please note: As these guidelines are concerned with reducing risks to marine mammals, all other notifications should be given as normal.

Existing protection

Section 9 of the Wildlife and Countryside Act 1981 prohibits deliberate killing, injuring or disturbance of any cetacean (equivalent in Northern Ireland is Article 10 of the Wildlife (Northern Ireland) Order 1985). This reflects the requirements of the Convention on the Conservation of European Wildlife and Habitats (the Bern Convention) and Article 12 of the EC Habitats and Species Directive (92/43/EEC), implemented by The Conservation (Natural Habitats, etc.) Regulations 1994 and The Conservation (Natural Habitats, etc.) Regulations Northern Ireland 1995.

In addition, the UK is a signatory to the Agreement on the Conservation of Small Cetaceans of the Baltic and North Seas and has applied its provisions in all UK waters. Amongst other actions required to conserve and manage populations of small cetaceans, the Agreement requires range states to "work towards....the prevention of ...disturbance, especially of an acoustic nature".

Marine mammal presence in UK waters

Records indicate there may be 22 species of cetacean either resident in, or passing through, UK waters. There are 9 regular visitors seen in coastal waters, the most common species of which are harbour porpoise, whitebeaked dolphin, bottlenose dolphin and common dolphin; the most common seen in deeper offshore seas are the long-finned pilot whale, common dolphin, harbour porpoise and killer whale. Northern right whales are very rare - they are an endangered species, having been hunted very close to extinction.

There are two species of seal which are resident in UK waters, the common or harbour seal and the grey seal. Both species breed in the UK, with common seals pupping in June/ July, and grey seals pupping from September to December, the exact timing depending on their location. Seals may be particularly vulnerable to disturbance during the pupping season. Other species, such as the hooded seal, may occasionally be seen in waters to the north of the UK.

Cues for detecting the presence of cetaceans

Even when quite close to vessels, cetaceans are often difficult to detect. The following points should help in ensuring that an adequate search has been made.

- Seismic operators should allow adequate time (at least 30 minutes) for sightings to be made prior to commencement of any use of the seismic sources
- The ease of detecting cetaceans declines with increasing sea state, so care should be taken to ensure an adequate search has been made in the prevailing conditions.
- Searches should be made from a high vantage point with a clear all-round view, e.g. the bridge roof or crow's nest. If necessary use two or more vantage points to give an all-round view.
- The sea should first be scanned slowly with the naked eye and then scanned slowly with binoculars.
- Hydrophones are a useful aid to detecting cetaceans. Cetaceans communicate with each other using whistles, creaks, chirps and moans which may be heard over considerable distances. Trains of clicks are used for echolocation and while foraging. They may be heard with a hydrophone at distances of several kilometres. In areas which are known to be frequented by small cetaceans,

any hydrophones used should be capable of receiving the high frequency sounds used by these animals.

- Submerged cetaceans are much more at risk than those on the surface. This makes it particularly important to use a hydrophone whenever possible to detect vocally active animals that may be invisible from the surface.
- Dolphins and porpoises generally surface 2-3 times per minute in order to breathe. Dive times and surfacing behaviour are more erratic when they are feeding, but most dives are unlikely to exceed 5 minutes. Large whales surface less often and may remain submerged for some time.
- Splashes may be a cue to the presence of cetaceans, although in seas rougher than sea state 2 cetacean splashes may be difficult to detect and distinguish from wave splashes.
- Blows of large whales may be more obvious, but still may be difficult to detect in strong winds.
- Some species may be attracted to boats from some distance away, probably by engine noise. They may accompany a vessel for a considerable period and even bowride if it is fast-moving. If possible, look over the bow of the ship to check for cetaceans close in to the ship which may be hidden from view from the normal vantage points. The arrays of hydrophones which are towed by survey vessels may also be attractive to dolphins.
- Feeding seabirds can sometimes be evidence of the presence of cetaceans. Species which are likely to associate with cetaceans include gannets, kittiwakes and Manx shearwaters, although any flock of birds should be checked for the possible presence of cetaceans.
- An oily slick at the sea surface may signify the presence of cetaceans. These slicks may also be attractive to birds such as fulmars and storm petrels.
- Cetaceans are capable of brief swimming speeds of 30 knots (34 mph), and sustained movement at 8 knots (10 mph), although some may swim at much slower speeds. If disturbed, they may alter their heading rapidly.

Seismic surveys

Modern large-scale surveys are conducted using towed arrays of "air-guns" - cylinders of compressed air. Each cylinder contains a small volume (typically between 10 and 100 cubic inches) at a pressure of about 2000 psi.

The array, typically containing some tens of such cylinders, is discharged simultaneously, to generate a pressure pulse which travels downwards into the sea bed. Some of this acoustic energy is emitted into the wider marine environment; however, the designers of air-gun arrays seek to maximise the transmission of energy into the sea bed, with the result that the energy dissipated into the wider environment is reduced. As a survey proceeds, the air-gun array is recharged with air from a compressor on board the towing vessel. The process is repeated at intervals of approximately ten seconds - the timing dependent on the objectives of the survey.

Potential effects of acoustic disturbance on cetaceans

The most prevalent form of acoustic disturbance in UK waters is probably the noise generated by boats; however, the noise caused by boat traffic is so widespread that many cetacean populations may have become used to it, although this does not necessarily mean that the animals are unaffected. The limited research on the effects of disturbance due to the passage of vessels shows there is some evidence that cetaceans will avoid approaching ships and may alter migration routes in response to marine traffic.

Effects of seismic surveys

The extent to which seismic disturbance from airguns affects cetaceans is not well known for all species, since only a limited amount of research has been done (see Annex for further details). Most

published research relates to the effect on large whales (particularly bowhead whales) of older air-gun arrays, which were different from those currently in use.

Seismic air-guns are designed to produce low frequency noise, generally below 200 Hz, used to build up a picture of the seabed and the underlying strata. However, recent research has shown that high frequency noise is also produced (Goold 1996a). Low frequency noise is more likely to disturb baleen whales than toothed dolphins; baleen whales communicate at frequencies mostly below 3 kHz, which are likely to overlap with the dominant frequencies used by seismic air-guns. The sensitivity of toothed dolphins to sound falls sharply below 1 kHz, and sounds below 0.2 kHz are probably inaudible to them. The sounds used by dolphins for communication are often above 4.8 kHz, and echolocation sounds can occur up to 200 kHz. Goold (1996a) found significant levels of energy across the recorded bandwidth up to 22 kHz. This high frequency noise, incidental to seismic operations, will overlap with the frequencies used by toothed dolphins, and could potentially cause disturbance. There is some evidence of disturbance of dolphins by seismic activity (Goold 1996b, Stone 1997, 1998).

Seismic activity could have a number of different effects on small cetaceans: it may interfere with communication or alter behaviour. In the worst case, there is some risk of physical damage in the immediate vicinity of air-guns. There is no evidence to suggest that injury has occurred to any cetacean in UK waters as a result of seismic activity, although such injuries may be difficult to detect. Seismic surveys may have indirect effects on local cetacean populations because of changes they may cause in the distribution of prey species.

The risk to cetaceans is increased by their natural inquisitiveness, and the fact that they may be attracted to areas of human activity where seismic surveying is about to take place.

Further information and comments on these guidelines

Standard forms (electronic and hard copy) are available for observers on seismic surveys. Please contact Mark Tasker at the address shown below. If you have any comments or questions on these guidelines, or suggestions on how they may be improved, please contact:

Zoe Crutchfield, (zoe.crutchfield@jncc.gov.uk)

Joint Nature Conservation Committee, Dunnet House, 7, Thistle Place, ABERDEEN, AB10 1UZ

Telephone 01224 655716

Fax 01224 621488

ANNEX

CONTACT NAMES AND ADDRESSES

Trevor Salmon, Department of the Environment, European Wildlife Division (TG 9/02), Tollgate House, Houlton Street, BRISTOL, BS2 9DJ

Telephone 0117 987 8854

Fax 0117 987 8642

(And, if requested to contact the Sea Mammal Research Unit)

Prof. John Harwood, Sea Mammal Research Unit, Gatty Marine Laboratory, University of St Andrews, St. Andrews, FIFE, KY16 8LB

Telephone 01334 462630

Fax 01334 462632

FURTHER INFORMATION

Davis et al. 1990. State of the Arctic Environment, Report on Underwater Noise. Prepared by LGL Ltd, PO Box 280, King City, Ontario, Canada L0G 1K0. Prepared for the Finnish Initiative on Underwater Noise. Provides a useful summary of the available scientific information of the possible effects of acoustic disturbance on cetaceans.

Environmental Guidelines for Exploration Operations in Nearshore and Sensitive Areas, published by the UK Offshore Operators Association, 3 Hans Crescent, London SW1X 0LN.

Evans, P.G.H. & Nice, H. 1996. Review of the effects of underwater sound generated by seismic surveys on cetaceans. Report to UKOOA, Sea Watch Foundation, Oxford.

Goold, J.C. 1996a. Broadband characteristics and propagation of air gun acoustic emissions in the southern Irish Sea. (in press).

Goold, J.C. 1996b. Acoustic assessment of populations of common dolphin *Delphinus delphis* in conjunction with seismic surveying *Journal of the Marine Biological Association* 76: 811-820.

Moscrop, A. & Simmonds, M. 1994. The threats posed by noise pollution and other disturbances to the health and integrity of cetacean populations around the UK. A report for the Whale and Dolphin Conservation Society, pp. 1-8. (Includes a review of work on acoustic disturbance of cetaceans). Available from the Whale and Dolphin Conservation Society, Alexander House, James Street West, Bath, Avon, BA1 2BT.

Richardson, W.J., Fraker, M.A., Würsig, B. & Wells, R. 1985. Behaviour of bowhead whales *Balaena mysticetus* summering in the Beaufort Sea: reactions to industrial activities. *Biological Conservation* 32: 195-230.

Richardson, W.J., Greene, C.R. Jr., Malme, C.I. & Thomson, D.H. 1995. *Marine mammals and noise*. Academic Press, San Diego.

Stone, C.J. 1997. Cetacean observations during seismic surveys in 1996. JNCC Reports, No. 228.

Stone, C.J. 1998. Cetacean observations during seismic surveys in 1997. JNCC Reports, No. 278.

Turnpenny, A.W.H. & Nedwell, J.R. 1994. The Effects on Marine Fish, Diving Mammals and Birds of Underwater Sound Generated by Seismic Surveys. Fawley Aquatic Research Laboratories Ltd, Fawley, Southampton SO45 1TW. (This includes an extensive further bibliography). Available from United Kingdom Offshore Operators Association, 3 Hans Crescent, London, SW1X 0LN.

USEFUL CETACEAN IDENTIFICATION GUIDES:

Cawardine, M. 1995. *Eyewitness handbooks - Whales, dolphins and porpoises*. Dorling Kindersley. ISBN 0- 7513-1030-1. Price £14.99. Available from bookshops.

Evans, P.G.H. 1995. *Guide to the identification of whales, dolphins and porpoises in European seas*. Sea Watch Foundation Publication, Oxford. Available from Sea Watch Foundation, Unit 29, Southwater Industrial Estate, Station Road, Southwater, West Sussex RH13 7UD. Price £5.00 + 50p p&p.

Leatherwood, S. & Reeves, R.R. 1983. *The Sierra Club handbook of whales and dolphins*. Sierra Club Books, San Francisco. ISBN 0-87156-341-X (hardback) ISBN 0-87156-340-1 (paperback). Available from some bookshops.

Sea Watch Foundation / BBC Wildlife 1994. *Identification guide to whales and dolphins of the British Isles*. Laminated wall chart available from Sea Watch Foundation Publication, Oxford. Available from Sea Watch Foundation, Unit 29, Southwater Industrial Estate, Station Road, Southwater, West Sussex RH13 7UD. Price £2.95 + £1.00 p&p.

Guidelines on the application of the Environment Protection and Biodiversity Conservation Act to interactions between offshore seismic operations and larger cetaceans October 2001

Purpose

The purpose of these Guidelines is to assist proponents of offshore seismic operations address certain of their obligations under the Environment Protection and Biodiversity Conservation Act 1999 (the Act) relevant to interactions with whales and certain other larger cetaceans.

Limitations

These Guidelines set out in plain English general advice about how Environment Australia intends to apply relevant provisions of the Act. They do not provide definitive advice relevant to any particular case. In each application of the Act, the particular circumstances of that case will need to be taken into account.

These Guidelines do not in any way fetter the discretion or responsibilities of the Minister for the Environment and Heritage or Environment Australia under the Act.

These Guidelines refer only to seismic operations and interactions with those cetaceans or whales listed at attachment 1. They do not relate to interactions with small cetaceans (such as dolphins) or other marine species (such as turtles or dugong). Whether a seismic survey will have a significant impact on a species at Attachment 3, other than those species listed at Attachment 1, should be considered prior to undertaking a survey. Other matters of national environmental significance such as the protection of World Heritage areas, Ramsar Convention listed wetlands of international importance, or the wider aspects of the Commonwealth marine environment trigger are also not addressed in these guidelines.

In relation to seismic operations and interactions with cetacean species other than those listed at Attachment 1, proponents need to determine the likelihood of the operation having a significant impact on the species or a population, or of interfering with individual animals of these species.

It is essential that all proponents make themselves familiar with the detail of their obligations under the Act. The Act can be found at www.ea.gov.au/epbc/about. The Government has separately published general Administrative Guidelines for the Act on whether a proposed action is likely to have a significant impact on any matter of national environmental significance. See www.ea.gov.au/epbc/assessapprov/guidelines/index.html or attachment 2.

When would a seismic operation that is likely to interact with whales require approval under Part 9 of the EPBC Act?

In the following circumstances a proposed seismic operation would be considered a 'controlled action' under the Act and so would require the approval of the Minister for the Environment and Heritage.

- Where a proposed seismic operation, whether in Commonwealth waters or in coastal waters, would be likely to have a significant impact on any threatened or migratory cetacean species. A full list of threatened or migratory cetacean species is at attachment 3.
- Where a seismic operation in Commonwealth waters would be likely to have a significant impact on any cetacean species.

Seismic operations will be regarded as being likely to have a significant impact on a cetacean species (including threatened and migratory cetacean species) in the following circumstances.

- Where the seismic operation is to be carried out in, or within 20 kilometres of, a feeding, breeding or resting area for a relevant cetacean species during the period when cetaceans are present.
 - The known feeding, breeding and resting areas for Southern right whales, Blue whales and Humpbacks - and the times when whales are believed to be present in these areas - are set out in the maps at Attachment 4. Areas for other species will be delineated in future as our knowledge increases.
- Under some circumstances seismic operations in or near migratory paths for cetaceans (as set out in maps at Attachment 5) at specified times may be likely to have a significant impact.
 - Proponents should consider referring relevant proposed operations in or near migratory paths to the Minister for decision on a case-by-case basis. Factors that may be relevant include: whether the migratory species is endangered; whether the seismic operations would be in a migratory path adjacent to a feeding, breeding or resting area; whether young calves or pregnant females may be affected; whether significant numbers (relative to the species or populations) of migrating cetaceans may be affected.

Should a proponent wish to remove uncertainty whether the action is a controlled action, the proposed action can be referred to the Minister for a decision about whether the action is a controlled action. Such a decision must be given in 20 days. (See section 75(5) of the Act.)

The undertaking of two surveys simultaneously in adjoining areas may lead to significantly greater interference than might be expected from a single survey and may lead to each of the surveys being considered to have a significant impact on the species.

When should you apply for a permit under Part 13 of the EPBC Act for a seismic operation that may interact with whales?

With limited exceptions, an action that will injure, take or interfere with a cetacean in Commonwealth waters is an offence under the Part 13 of the Act unless a permit has been granted. In general, permits will not be granted to injure or take cetaceans. Accordingly, these two circumstances will not be considered further here.

A seismic operation that would interfere with a cetacean in Commonwealth waters would not be an offence under Part 13 of the Act if a permit has been granted.

Interference is defined in the Act to include harass, chase, herd, tag, mark or brand the cetacean. For the purposes of these Guidelines a precautionary approach has been taken to the definition of interference; that is causing a significant change in behaviour, including a significant deviation from their migratory path or a substantial change in respiration or swimming pattern, will be considered harassment and so interference.

Under the following circumstances Environment Australia may consider a seismic operation as interfering with a cetacean.

- Where a seismic operation is a controlled action under Part 3 of the Act (and so must be approved by the Minister) as a result of its potential interactions with cetaceans. In these cases the permitting and approvals processes will be managed together.
- Seismic operations that are not controlled actions under Part 3 of the Act, but nonetheless take place in or near migratory paths around the time when migrations may occur. Such seismic operations may cause any present whales to modify their behaviour (for example deviate from their migratory path) and so may interfere with them.
 - Maps of migratory pathways for Humpback whales, Blue whales and Southern right whales are at attachment 5. Seismic operations in these areas during the peak of the Humpback migratory season and for all of the Blue whale and Southern right whale migratory season will be considered to be likely to interfere with any present whales. As areas important for other species become known, additional areas will be delineated.

In general, a seismic operation will **not** be regarded as interfering with cetaceans under the following circumstances.

- The seismic operation will take place outside of the migratory pathways and migration period for whales and outside of the breeding, feeding and resting areas during the times when these areas are occupied; and
- the management prescriptions set out in attachment 6 are observed.
 - These management prescriptions are intended to ensure that the proponent will take proper efforts to identify whether whales are in the area where seismic operations are to commence, and should there be whales in the area that every reasonable effort is taken to undertake the seismic operations in a manner that eliminates or minimizes impacts on them.

What is the relationship between Part 3 approvals and Part 13 permitting processes in the Act?

From the above it is clear that, given the different objectives of the approvals and permitting provisions under the Act, proponents of seismic operations should have regard to a number of possible outcomes. These are broadly set out below.

Some seismic operations will not require an approval and nor will the permit provisions apply.

- That is, where there is no significant impact on a cetacean species and there is no interference with any individual cetacean (and other NES matters are not affected).

For some seismic operations only the permit provisions will apply.

- For example, where a seismic operation in Commonwealth waters may interfere with migrating whales the permit provisions will apply, but if a significant impact on the species or a population of species is not likely no approval will be required.

Some seismic operations will require approval but the permit provisions will not apply.

- For example, a seismic operation in coastal waters that is likely to impact significantly on a population of a threatened cetacean will require approval. However, because the action is in coastal waters (and not Commonwealth waters) the permit provisions would not apply.

For some seismic operations in Commonwealth waters, both an approval will be required and the permit provisions will apply.

- This will be the case where a proposal will have both a significant impact on a species of cetacean and will also interfere with individual cetaceans. In such cases, approvals and permits will be processed together to avoid any delay or duplication. For practical purposes, there will be one process and the same documentation from the proponent can be used to meet both requirements.

What do you have to do for the Part 3 approvals process?

Where a proposed action has been referred to the Minister for the Environment and Heritage and found to have or be likely to have a significant impact on a matter of national environmental significance (a controlled action), the action will require the approval of the Minister. The process for obtaining approval is outlined at Attachment 7. Further information on the process can be gained at www.ea.gov.au/epbc/assessapprov/index.html.

What do you have to do for the Part 13 permitting process?

Under the EPBC Act applying for a permit to undertake an action that may interfere with a cetacean automatically requires that the action be treated like a controlled action.

From this step a similar process as described for the Part 3 approval is followed, though at the end of the process a permit is issued (or refused) rather than an approval being given (or refused). Conditions may be placed on the permit.

The permit process has a simultaneous step of advising persons on the Register for consultation about permits of the permit application and seeking their comment on the application.

Standard Conditions

As a general rule proponents of seismic operations should expect to be subject to conditions applying to approvals or permits.

The conditions will be based on the set of management prescriptions set out at Attachment 6. These are for guidance only and specific conditions will be determined for each proposal depending on the particular circumstances of the operational environment.

In general these conditions are intended to ensure that:

- every reasonable effort is taken to identify whether whales are in the vicinity of a seismic operation;
- should whales be in the vicinity, avoidance of interference and mitigating action takes place, and
- if whales do not appear to be in the vicinity, the operation is commenced and managed in a precautionary manner to minimise interference with whales that may not have been identified and to cease operations quickly should whales be identified and interference be avoidable.

Supporting notes

Feeding, breeding and resting areas

Whales that are feeding, breeding and resting (in particular with calves) are considered susceptible to disturbance. Generally the conditions supporting these activities are unlikely to be available in other locations. Disturbing whales under these circumstances is likely to have an impact on the population of the species. The sensitivity of cow/calf pairs to disturbance when resting during migrations requires that a substantial buffer of 20 kilometres around these resting areas is applied to allow the calves to regain strength for the migration.

Migratory paths

Generally whales are robust animals able to travel long distances. Under most circumstances, a whale making a small deviation within its general migratory path to avoid seismic operation is unlikely to be adversely affected in terms of successful migration. However, in some circumstances precautionary management suggests that causing such deviations should be avoided where possible. These would best be judged on a case-by-case basis, considering factors such as the conservation status of the relevant species, or the likelihood of young calves or pregnant females being in the area.

Sound levels

The impact of sound from seismic sources is the subject to ongoing work in many parts of the world, including Australia. The impact of disturbance on whales in the short and long term is also unknown. Evidence to date shows that sounds heard by whales of over approximately 140db in feeding, breeding or resting areas may be considered likely to significantly disturb whales that are present. Sounds heard by whales of over 150db in other areas, such as migratory paths, may significantly disturb whales that are in the area. A document outlining the current justification for these sound levels is available from Environment Australia).

Contact

For further information on the operation of these guidelines contact:

Director
Marine Species Section
Environment Australia
GPO Box 787
CANBERRA ACT 2601

Environment Australia, October 2001
ISBN 064254784X

Attachment 1

List of whales species to which these guidelines relate

Common name	Scientific name
Shepherd's beaked whale	<i>Tasmacetus shepherdii</i>
Dense-beaked whale	<i>Mesoplodon densirostris</i>
Hector's beaked whale	<i>Mesoplodon hectori</i>
Longman's beaked whale	<i>Mesoplodon pacificus</i>
Andrew's beaked whale	<i>Mesoplodon bowdoini</i>
True's beaked whale	<i>Mesoplodon mirus</i>
Ginkgo-toothed beaked whale	<i>Mesoplodon ginkgodens</i>
Strap-toothed whale	<i>Mesoplodon layardii</i>
Gray's beaked whale	<i>Mesoplodon grayi</i>
Arnoux's beaked whale	<i>Berardius arnuxii</i>
Cuvier's beaked whale	<i>Ziphius cavirostris</i>
Killer whale	<i>Orcinus orca</i>
Long-finned pilot whale	<i>Globicephala melas</i>
Short-finned pilot whale	<i>Globicephala macrorhynchus</i>
Southern bottlenose whale	<i>Hyperoodon planifrons</i>
Sperm whale	<i>Physeter macrocephalus</i>
Southern right whale	<i>Eubalaena australis</i>
Pygmy right whale	<i>Caperea marginata</i>
Minke whale	<i>Balaenoptera acutorostrata</i>
Sei whale	<i>Balaenoptera borealis</i>
Bryde's whale	<i>Balaenoptera edeni</i>
Blue whale	<i>Balaenoptera musculus</i>
Fin whale	<i>Balaenoptera physalus</i>
Humpback whale	<i>Megaptera novaeangliae</i>

Attachment 2

Criteria for significance under the three matters of NES, listed threatened species, Listed migratory species and Commonwealth marine environment.

Listed Critically endangered and endangered species

An action will require approval from the Environment Minister if the action has, will have, or is likely to have a significant impact on a listed critically endangered or endangered species.

Criteria

An action has, will have, or is likely to have a significant impact on a critically endangered or endangered species if it does, will, or is likely to:

1. lead to a long-term decrease in the size of a population,
2. or reduce the area of occupancy of the species, or fragment an existing population into two or more populations,
3. or adversely affect habitat critical to the survival of a species,
4. or disrupt the breeding cycle of a population, or
5. modify, destroy, remove, isolate or decrease the availability or quality of habitat to the extent that the species is likely to decline, or
6. result in invasive species that are harmful to a critically endangered or endangered species becoming established in the endangered or critically endangered species' habitat*,
7. or interfere with the recovery of the species.

(*Introducing an invasive species into the habitat may result in that species becoming established. An invasive species may harm a critically endangered or endangered species by direct competition, modification of habitat, or predation.)

Listed Vulnerable species

An action will require approval from the Environment Minister if the action has, will have, or is likely to have a significant impact on a listed vulnerable species.

Criteria

An action has, will have, or is likely to have a significant impact on a vulnerable species if it does, will, or is likely to:

1. lead to a long-term decrease in the size of an *important* population of a species,
2. or reduce the area of occupancy of an *important* population, or
3. fragment an existing *important* population into two or more populations, or
4. adversely affect habitat critical to the survival of a species, or
5. disrupt the breeding cycle of an *important* population, or
6. modify, destroy, remove or isolate or decrease the availability or quality of habitat to the extent that the species is likely to decline, or
7. result in invasive species that are harmful a vulnerable species becoming established in the vulnerable species' habitat*, or
8. interferes substantially with the recovery of the species.

(* Introducing an invasive species into the habitat may result in that species becoming established. An invasive species may harm a vulnerable species by direct competition, modification of habitat, or predation.)

An important population is one that is necessary for a species' longterm survival and recovery. This may include populations that are:

1. key source populations either for breeding or dispersal,
2. populations that are necessary for maintaining genetic diversity, and/or
3. populations that are near the limit of the species range.

In addition to the above information, Commonwealth adopted Recovery Plans may also provide further guidance on whether an action is likely to be significant.

Listed Migratory Species

An action will require approval from the Environment Minister if the action has, will have, or is likely to have a significant impact on a listed migratory species.

Criteria

An action has, will have, or is likely to have a significant impact on a migratory species if it does, will, or is likely to:

1. substantially modify (including by fragmenting, altering fire regimes, altering nutrient cycles or altering hydrological cycles), destroy or isolate an area of important habitat of the migratory species, or
2. result in invasive species that is harmful to the migratory species becoming established* in an area of important habitat of the migratory species, or
3. seriously disrupt the lifecycle (breeding, feeding, migration or resting behaviour) of an ecologically significant proportion of the population of the species.

(* Introducing an invasive species into the habitat may result in that species becoming established. An invasive species may harm a migratory species by direct competition, modification of habitat, or predation.)

An area of important habitat is:

1. Habitat utilised by a migratory species occasionally or periodically within a region that supports an ecologically significant proportion of the population of the species, or
2. habitat utilised by a migratory species which is at the limit of the species range, or
3. habitat within an area where the species is declining.

Listed migratory species cover a broad range of species with different life cycles and population sizes. Therefore, what is an ecologically significant proportion of the population varies with the species (each circumstance will need to be evaluated)

Commonwealth marine environment

An action will require approval from the Environment Minister if the action has, will have, or is likely to have a impact on the environment of the Commonwealth marine area.

Criteria

An action has, will have or is likely to have a significant impact on the environment in a Commonwealth marine area if it does, will, or is likely to:

1. result in a known or potential pest species becoming established in the Commonwealth marine area*, or
2. modify, destroy, fragment, isolate or disturb an important or substantial area of habitat such that an adverse impact on marine ecosystem functioning or integrity in a Commonwealth marine area results, or
3. have a substantial adverse effect on a population of a marine species or cetacean including its life cycle (eg breeding, feeding, migration behaviour, and life expectancy) and spatial distribution, or
4. result in a substantial change in air quality** or water quality (including temperature) which may adversely impact on biodiversity, ecological integrity, social amenity or human health, or
5. result in persistent organic chemicals, heavy metals, or other potentially harmful chemicals accumulating in the marine environment such that biodiversity, ecological integrity, social amenity or human health may be adversely affected.

(* Translocating or introducing a pest species may result in that species becoming established.

** The Commonwealth marine area includes any airspace over Commonwealth waters.)

Guidelines for the Mining Industry

Guidelines on significance have been published for the mining industry. These include a reference to seismic activity in the marine environment which states:

'Seismic exploration (using air guns) is not likely to have a significant impact on a matter of national environmental significance unless the activity is undertaken in an area that contains habitat for threatened or migratory species and the seismic activity is likely to interfere with breeding, feeding or migration. Similarly, seismic exploration using air guns would not normally be expected to have a significant impact on the Commonwealth marine environment unless it was undertaken in an area that contains habitat for threatened or migratory species and the seismic activity is likely to interfere with breeding, feeding or migration. In addition, seismic activity in shallow or near shore environments in or adjacent to a Commonwealth marine area or a Ramsar wetland is likely to have a significant impact on a matter of national environmental significance.'

Attachment 3

Cetaceans occurring in Australian waters that are listed as a listed threatened species or a listed migratory species or both.

At least 44 species of cetaceans have been reported in Australian and Antarctic waters. This includes 26 species of whale, 17 species of dolphins and one species of porpoise (which occurs in sub-Antarctic waters).

Five of the whale species found in Australian waters are also considered threatened and are listed as endangered or vulnerable under the Act. In addition, a number of the whale and dolphin species are migratory (visiting Australia for only part of the year or having populations that straddle international borders) and are listed under the Convention on the Conservation of Migratory Species of Wild Animals (the CMS or Bonn Convention).

Both a listed critically endangered or endangered species and a listed migratory species

Blue whale (*Balaenoptera musculus*) - Appendix 1 Bonn Convention
Southern right whale (*Eubalaena australis*)

Both a listed vulnerable species and a listed migratory species

Humpback whale (*Megaptera novaeangliae*) - Appendix 1 Bonn Convention

Listed vulnerable species

Sei whale (*Balaenoptera borealis*)
Fin whale (*Balaenoptera physalus*)

Listed migratory species

Spectacled porpoise (*Phocoena diotropica*) - listed Appendix 2 Bonn Convention
Indo-Pacific humpback dolphin (*Sousa chinensis*)
Dusky dolphin (*Lagenorhynchus obscurus*)
Indian Ocean bottlenose dolphin (*Tursiops aduncus*)
Pantropical spotted dolphin (*Stenella attenuata*)
Spinner dolphin (*Stenella longirostris*)
Fraser's dolphin (*Lagenodelphis hosei*)
Irrawaddy dolphin (*Orcaella brevirostris*)

All cetaceans occurring in Commonwealth waters are protected. The impact a proposal may have on an important population of any cetacean species is considered under the marine environment matter of National Environmental Significance. A permit is required to interfere with any individual cetacean of any species within Commonwealth areas

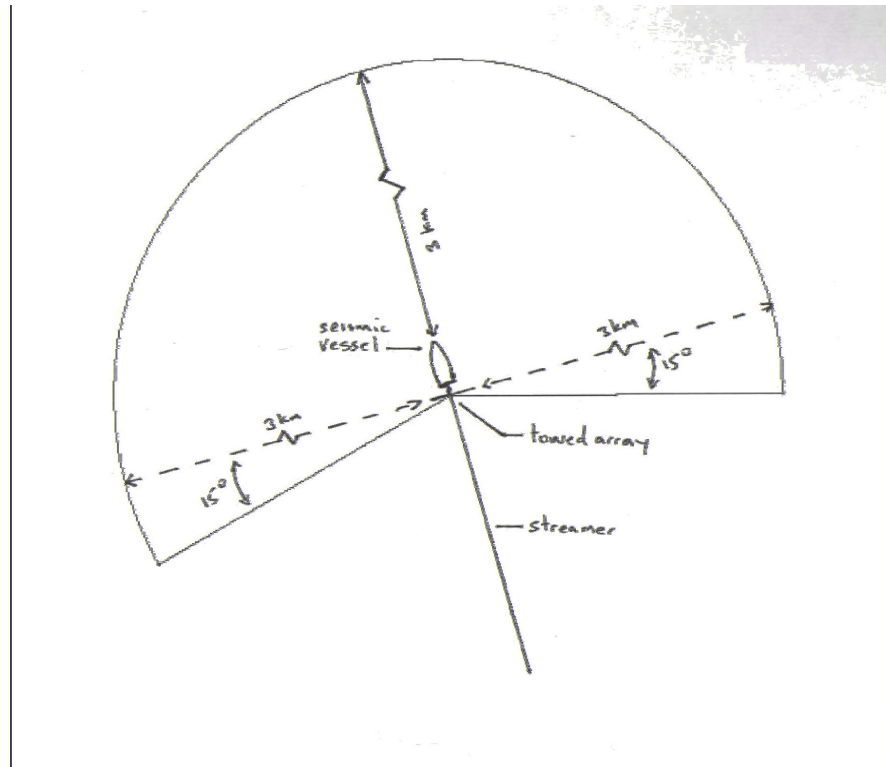

Diagram of area surrounding a seismic vessel that must be monitored for the presence of whales

Southern Right Whales

distribution, migration and
aggregated areas

- Legend**
- Breeding areas (BZ)
 - mid May - end September
 - Known migratory pathways
 - Migration seasons
 - mid May - end September (BZ)
 - early September - mid October (BZ)
 - early May - mid June (BZ)
 - Australian Coastline
 - Exclusive Economic Zone (200 km)

All data used are assumed to be correct as
of the date supplied.

© 2000 Australian Coastline and Data
Centre

© 1997 Australian Maritime Boundary
Commission (AMBC)

Southern Right Whale distribution
and aggregated areas in
this report

Prepared by Environment Australia
on behalf of Australia, Canberra
July 2000
1999/01
Environment of Australia, 1999

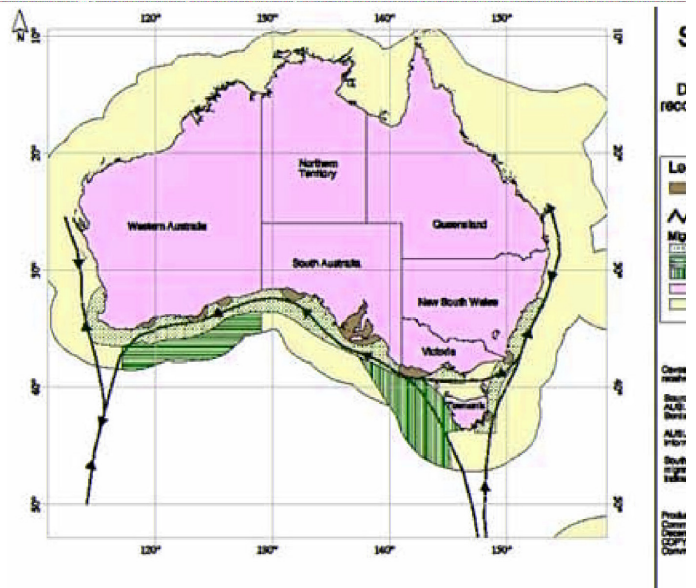
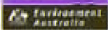

ERROR: undefined

OFFENDING COMMAND: FF

STACK: